

---

## AT-130 AT-130E AT-140 AT-141

---

### CONTENTS

REPLACEMENT PAGES .....	6-1 and 6-2
PARTS LIST .....	1
BOARD LAYOUTS .....	8
VOLTAGE DIAGRAM .....	10

### [UNIT LIST]

Model	Version	Vesion Number
AT-130	USA-5	[#41]
	CHN	[#47]
AT-130E	EUR-2	[#42]
AT-140	USA-6	[#46]
	CHN	[#50]
AT-141	EUR	[#43]
	EUR-1	[#44]
	CHN	[#48]
	CHN-01	[#49]

# SECTION 6 MECHANICAL PARTS

**[UNIT LIST]**

Model	Version	Vesion Number
AT-130	USA-5	[#41]
	CHN	[#47]
AT-130E	EUR-2	[#42]
AT-140	USA-6	[#46]
	CHN	[#50]
AT-141	EUR	[#43]
	EUR-1	[#44]
	CHN	[#48]
	CHN-01	[#49]

**[CHASSIS PARTS]**

REF NO.	ORDER NO.	DESCRIPTION	QTY.	
MP538	8810001691	SCREW PH M3 X 8 ZC3	[#41] 9	
	8810001691	SCREW PH M3 X 8 ZC3	[#42] 6	
	8810001691	SCREW PH M3 X 8 ZC3	[#43] 9	
	8810001691	SCREW PH M3 X 8 ZC3	[#44] 9	
	8810001691	SCREW PH M3 X 8 ZC3	[#46] 9	
	8810001691	SCREW PH M3 X 8 ZC3	[#47] 9	
	8810001691	SCREW PH M3 X 8 ZC3	[#48] 9	
	8810001691	SCREW PH M3 X 8 ZC3	[#49] 9	
	8810001691	SCREW PH M3 X 8 ZC3	[#50] 9	
	MP539	8830000240	NUT M 4 SUS	10
MP540	8860000160	EARTH RUG B 8 (M5) AG BS	1	
MP541	8930006570	SEALING WASHER (D)	1	
MP544	8930006570	SEALING WASHER (D)	1	
MP545	8930006550	SEALING WASHER (A)	[#41] 1	
	8930006550	SEALING WASHER (A)	[#42] 1	
	8930006550	SEALING WASHER (A)	[#47] 1	
MP548	8930010361	SPASER D=4 L=28 T=0.6 ZC3	Only [#42] 3	
MP549	8810004261	PHB1 M3 X40 ZC3	Only [#42] 3	
MP550	8850000130	FLAT WASHER M3 (3X8X0.5)NI BS	Only [#42] 3	
MP551	8950001980	CABLE TIE GT-140I	[#43] 1	
	8950001980	CABLE TIE GT-140I	[#44] 1	
	8950001980	CABLE TIE GT-140I	[#46] 1	
	8950001980	CABLE TIE GT-140I	[#48] 1	
	8950001980	CABLE TIE GT-140I	[#49] 1	
	8950001980	CABLE TIE GT-140I	[#50] 1	
	MP552	6910014570	FGA13-08B <KOU>	[#43] 1
	6910014570	FGA13-08B <KOU>	[#44] 1	
	6910014570	FGA13-08B <KOU>	[#46] 1	
	6910014570	FGA13-08B <KOU>	[#48] 1	
	6910014570	FGA13-08B <KOU>	[#49] 1	
	6910014570	FGA13-08B <KOU>	[#50] 1	
	MP553	6910014570	FGA13-08B <KOU>	[#43] 1
	6910014570	FGA13-08B <KOU>	[#44] 1	
	6910014570	FGA13-08B <KOU>	[#46] 1	
6910014570	FGA13-08B <KOU>	[#48] 1		
6910014570	FGA13-08B <KOU>	[#49] 1		
MP554	8950001980	CABLE TIE GT-140I	[#43] 1	
	8950001980	CABLE TIE GT-140I	[#44] 1	
	8950001980	CABLE TIE GT-140I	[#46] 1	
	8950001980	CABLE TIE GT-140I	[#48] 1	
	8950001980	CABLE TIE GT-140I	[#49] 1	
MP556	8930059800	2600 PET SHEET	[#43] 2	
	8930059800	2600 PET SHEET	[#44] 2	
	8930059800	2600 PET SHEET	[#46] 2	
	8930059800	2600 PET SHEET	[#48] 2	
	8930059800	2600 PET SHEET	[#49] 2	
	8930059800	2600 PET SHEET	[#50] 2	
	MP557	8930049320	2288 VENT.SHEET	[#43] 2
		8930049320	2288 VENT.SHEET	[#44] 2
		8930049320	2288 VENT.SHEET	[#46] 2
		8930049320	2288 VENT.SHEET	[#48] 2
8930049320		2288 VENT.SHEET	[#49] 2	
MP558	8930047350	INSULATION SHEETFK	2	
MP559	8850000180	FLAT WASHER M 5 SUS	1	
MP560	8930006570	SEALING WASHER (D)	1	

**[CHASSIS PARTS]**

REF NO.	ORDER NO.	DESCRIPTION	QTY.	
W501	8900014990	OPC-1468	[#43] 1	
	8900014990	OPC-1468	[#44] 1	
	8900013500	OPC-1146N	[#46] 1	
	8900014990	OPC-1468	[#48] 1	
	8900014990	OPC-1468	[#49] 1	
W502	8900013500	OPC-1146N	[#50] 1	
	8900011401	OPC-1164-1 <GA>	[#43] 1	
	8900011401	OPC-1164-1 <GA>	[#44] 1	
	8900011401	OPC-1164-1 <GA>	[#46] 1	
	8900011401	OPC-1164-1 <GA>	[#48] 1	
	8900011401	OPC-1164-1 <GA>	[#49] 1	
	8900011401	OPC-1164-1 <GA>	[#50] 1	
EP501	6910000880	NC-1 (SUS)	[#41] 1	
	6910000880	NC-1 (SUS)	[#42] 1	
EP502	6910000880	NC-1 (SUS)	[#47] 1	
	6910000880	NC-1 (SUS)	[#41] 1	
	6910000880	NC-1 (SUS)	[#42] 1	
	6910000880	NC-1 (SUS)	[#47] 1	
MP502	8010003411	CASE (A)-1 EX404	[#41] 1	
	8010016911	CASE (I)-1 EX1157	[#42] 1	
	8010019030	1157 U-CASE (404CASE )	[#43] 1	
	8010019030	1157 U-CASE (404CASE )	[#44] 1	
	8010019030	1157 U-CASE (404CASE )	[#46] 1	
	8010003411	CASE (A)-1 EX404	[#47] 1	
	8010019030	1157 U-CASE (404CASE )	[#48] 1	
	8010019030	1157 U-CASE (404CASE )	[#49] 1	
	8010019030	1157 U-CASE (404CASE )	[#50] 1	
	MP503	8010003331	CASE (B)-1 EX404	[#41] 1
		8010016921	CASE (J)-1 EX1157	[#42] 1
		8010019020	1157 L-CASE (404CASE )	[#43] 1
		8010019020	1157 L-CASE (404CASE )	[#44] 1
		8010019020	1157 L-CASE (404CASE )	[#46] 1
		8010003331	CASE (B)-1 EX404	[#47] 1
8010019020		1157 L-CASE (404CASE )	[#48] 1	
8010019020		1157 L-CASE (404CASE )	[#49] 1	
8010019020		1157 L-CASE (404CASE )	[#50] 1	
MP504		8930006900	MOUNTING PLATE	2
MP505	8930006540	WATERPROOF SEAL	1	
MP506	8930002800	O-RING (G)	[#41] 2	
	8930002800	O-RING (G)	[#42] 2	
	8930002800	O-RING (G)	[#47] 2	
	8930002800	O-RING (G)	[#48] 2	
MP507	8930006550	SEALING WASHER (A)	[#41] 1	
	8930006550	SEALING WASHER (A)	[#42] 1	
	8930006550	SEALING WASHER (A)	[#47] 1	
MP508	8930006560	SEALING WASHER (C)	1	
MP509	8930006570	SEALING WASHER (D)	4	
MP510	6910000470	PAIR INSULATOR	1	
MP519	8810003480	HEXBOLT M5 X60 SUS	1	
MP520	8930045522	1869 SCREW PLATE-2	1	
MP521	8850000500	S-WASHER M 5 SUS	1	
MP522	8850000180	FLAT WASHER M 5 SUS	1	
MP523	8830000250	NUT M 5 SUS	1	
MP524	8860000190	EARTH RUG D 5 (M5) AG BS	1	
MP525	8850000600	GEAR WASHER M 5 SUS	1	
MP526	8830000370	WING NUT M 5 SUS	1	
MP527	8810003470	HEXBOLT M5 X20 SUS	1	
MP528	8930045522	1869 SCREW PLATE-2	1	
MP530	8850000180	FLAT WASHER M 5 SUS	1	
MP531	8830000250	NUT M 5 SUS	1	
MP532	8860000190	EARTH RUG D 5 (M5) AG BS	1	
MP533	8850000600	GEAR WASHER M 5 SUS	1	
MP534	8830000370	WING NUT M 5 SUS	1	
MP535	8810002800	SCREW TRASS M5 X10 SUS	4	
MP536	8810000660	PH M4 X14 SUS	10	
MP537	8810001480	PHA M5 X10 SUS	[#41] 2	
	8810001480	PHA M5 X10 SUS	[#42] 2	
	8810001480	PHA M5 X10 SUS	[#47] 2	

\*: Refer to "BOARD LAYOUTS" for the location.

\*\* : Refer to "VOLTAGE DIAGRAM" for the connection

**Screw abbreviations** A, B0, BT: Self-tapping PH: Pan head ZK: Black NI-ZU: Nickel-Zinc SUS: Stainless

[TUNER-1 UNIT]

REF NO.	ORDER NO.	DESCRIPTION	QTY.
WS5	8600030531	EX1157 P01TU-1 (#0212)	Only [#42] 1
J1*	6510028410	MR-DS-01-1 <GA>	1
	6510028410	MR-DS-01-1 <GA>	1
	6510028410	MR-DS-01-1 <GA>	1
J4*	6910003141	IMSA-9202B-1-02Z041-PT1	1
J6*	6910003141	IMSA-9202B-1-02Z041-PT1	1
J9*	6510015150	ML-800S1V-6P	1
	6510015150	ML-800S1V-6P	1
	6510015150	ML-800S1V-6P	1
J13*	6910003141	IMSA-9202B-1-02Z041-PT1	1
J16*	6510003101	RT01T-1.3B (LF)	1
	6510003101	RT01T-1.3B (LF)	1
	6510003101	RT01T-1.3B (LF)	1
J21*	6510003101	RT01T-1.3B (LF)	1
	6510003101	RT01T-1.3B (LF)	1
	6510003101	RT01T-1.3B (LF)	1
P4**	6910003120	IMSA-9206H-T	1
P6**	6910003120	IMSA-9206H-T	1
S1*	2260000200	MS621C	1
	2260000200	MS621C	1
	2260000200	MS621C	1
	2260000200	MS621C	1
	2260000200	MS621C	1
S2*	2260001890	SKQDPA	1
S3*	2260002881	HDS408C-E	1
	2260002881	HDS408C-E	1
	2260002881	HDS408C-E	1
	2260002881	HDS408C-E	1
	2260002881	HDS408C-E	1
S4*	2260002881	HDS408C-E	1
	2260002881	HDS408C-E	1
	2260002881	HDS408C-E	1
	2260002881	HDS408C-E	1
	2260002881	HDS408C-E	1
S5*	2260002881	HDS408C-E	1
	2260002881	HDS408C-E	1
	2260002881	HDS408C-E	1
	2260002881	HDS408C-E	1
	2260002881	HDS408C-E	1
W18	9011570360	35/00/110/W06/W06	1
W19	9045201001	74/98/040/X98/X98	1
	9045201001	74/98/040/X98/X98	1
W20*	9011570470	74/98/038/X98/X98	1
	9011570470	74/98/038/X98/X98	1
W21*	9011570400	13/01/065/W04/W04	Only [#42] 1
W61*	9011570480	99/09/150/W06/W06 AWM3239 30K	Only [#42] 1
MP1	8930006912	CONNECTOR ANGLE-2	1
	8930006912	CONNECTOR ANGLE-2	1
	8930006912	CONNECTOR ANGLE-2	1
MP3	8510001102	117 SHIELD COVER (A)-2	1
MP4	8510001082	117 SHIELD CASE (A)-2	1
MP6	8510003500	406SHIELD CASE	1
MP7	8510002020	MIXSHIELD CASE SX155	1
MP9	8810003171	SET SCREWA M3 X 8 ZC3	2
	8810003171	SET SCREWA M3 X 8 ZC3	2
	8810003171	SET SCREWA M3 X 8 ZC3	2
MP10	8810003161	SET SCREWA M3 X 6 ZC3	2
	8810003161	SET SCREWA M3 X 6 ZC3	2
	8810003161	SET SCREWA M3 X 6 ZC3	2
MP11	8510003500	406SHIELD CASE	1
MP12	8510003510	406SHIELD CASE COVER	1
MP16	6910008240	59TN4772 (SPCC)	1
	6910008240	59TN4772 (SPCC)	1
	6910008240	59TN4772 (SPCC)	1
MP17	8860000130	EARTH RUG B 5 (M3) AG BS	Only [#42] 1
MP18	8930000230	STAT (S)	Only [#42] 1
MP19	8830000191	NUT M3 BS-CD NI	Only [#42] 1
MP20	8930017191	EARTH SPRING (F)-1	Only [#42] 2
MP21	8810003291	SET SCREWB M3 X 6 ZC3	Only [#42] 1
MP22	8510003500	406SHIELD CASE	1
MP23	8510003510	406SHIELD CASE COVER	1

[ACCESSORIES]

REF NO.	ORDER NO.	DESCRIPTION	QTY.
J701	6510002030	1380TL	4
	6510002030	1380TL	4
	6510002030	1380TL	4
	6510002030	1380TL	4
	6510002030	1380TL	4
	6510002030	1380TL	4
P701	6510002050	1190T L	4
	6510002050	1190T L	4
	6510002050	1190T L	4
P702	6510001930	1490P1	1
W701	8900004200	OPC-412	1
MP701	8820000440	UBOLT A SUS	2
MP702	8010000010	U-BOLT PLATE	2
MP703	8830000260	NUT M 6 SUS	4
MP704	8850000510	S-WASHER M 6 SUS	4
MP705	8850000190	FLAT WASHER M 6 (6X13X1.0)SUS	4
MP706	8810001500	PHA M6 X30 SUS	4
MP707	8810003500	HEXBOLT M6 X50 SUS	4
MP708	8850000200	FLAT WASHER M 6 (6X20X1.5)SUS	8
MP709	8830000260	NUT M 6 SUS	4
MP710	8850000510	S-WASHER M 6 SUS	4
MP711	6950000010	WATERPROOF CAP (WHITE)	1

\*: Refer to "BOARD LAYOUTS" for the location.

\*\* : Refer to "VOLTAGE DIAGRAM" for the connection

Screw abbreviations A, B0, BT: Self-tapping PH: Pan head ZK: Black NI-ZU: Nickel-Zinc SUS: Stainless

# PARTS LIST

**[UNIT LIST]**

Model	Version	Vesion Number
AT-130	USA-5	[#41]
	CHN	[#47]
AT-130E	EUR-2	[#42]
AT-140	USA-6	[#46]
	CHN	[#50]
AT-141	EUR	[#43]
	EUR-1	[#44]
	CHN	[#48]
	CHN-01	[#49]

**[TUNER-1 UNIT]**

REF NO.	PARTS NO.	DESCRIPTION	M.	H/V LOCATION
IC2	1130011760	S.IC CD4094BPWR	T	64.3/127.9
IC3	1130011760	S.IC CD4094BPWR	T	64.3/147.1
IC4	1130011760	S.IC CD4094BPWR	T	64.3/166.2
IC5	1130008411	S.IC TC74AC393F(ELF)	T	30.6/128.3
IC6	1130007111	S.IC TC7W04FU(TE12LF)	T	31.3/162.1
IC7	1110005791	S.IC S-80841CLUA-B62T2G	T	30.9/174.0
IC11	1160000120	S.IC UPA2004GR-E2	T	104.0/130.0
IC12	1160000120	S.IC UPA2004GR-E2	T	104.0/145.4
IC13	1160000120	S.IC UPA2004GR-E2	T	104.0/160.1
IC14	1160000120	S.IC UPA2004GR-E2	T	104.0/174.9
IC15	1140013393	S.IC MB95F108AHSPMC-G-JNE1 (1157A-1) [#41]	T	38.9/151.0
	1140013392	S.IC MB95F108AHSPMC-GE1 (1157A-1) [#42]		
	1140013393	S.IC MB95F108AHSPMC-G-JNE1 (1157A-1) [#43]		
	1140013393	S.IC MB95F108AHSPMC-G-JNE1 (1157A-1) [#44]		
	1140013393	S.IC MB95F108AHSPMC-G-JNE1 (1157A-1) [#46]		
	1140013393	S.IC MB95F108AHSPMC-G-JNE1 (1157A-1) [#47]		
	1140013393	S.IC MB95F108AHSPMC-G-JNE1 (1157A-1) [#48]		
	1140013393	S.IC MB95F108AHSPMC-G-JNE1 (1157A-1) [#49]		
	1140013393	S.IC MB95F108AHSPMC-G-JNE1 (1157A-1) [#50]		
IC16	1130007111	S.IC TC7W04FU(TE12LF) [#41]	T	63.5/178.3
	1130007111	S.IC TC7W04FU(TE12LF) [#42]		
	1130007111	S.IC TC7W04FU(TE12LF) [#46]		
	1130007111	S.IC TC7W04FU(TE12LF) [#47]		
	1130007111	S.IC TC7W04FU(TE12LF) [#50]		
IC17	1130013081	S.IC S-24CS08AFT-TB-1G	T	47.8/135.8
IC18	1130007261	S.IC TC7W74FU(TE12LF)	T	31.3/168.2
IC19	1110001592	S.IC TA75393FG(5EL)	T	27.4/43.5
IC20	1180001072	S.IC TA7805F(TE16L1NQ)	T	13.4/150.0
Q2	1530002691	S.TRA 2SC4116-GR(TE85RF)	T	32.5/68.5
Q3	1590004750	S.TRA LMUN5213T1G <SLVJ>	T	27.2/27.2
Q4	1530002691	S.TRA 2SC4116-GR(TE85RF)	T	46.7/25.2
Q5	1530002691	S.TRA 2SC4116-GR(TE85RF)	T	43.5/25.2
Q7	1510000771	S.TRA 2SA1586-GR(TE85LF)	T	25.0/178.6
Q8	1530002691	S.TRA 2SC4116-GR(TE85RF)	T	37.6/175.1
Q9	1590004750	S.TRA LMUN5213T1G <SLVJ> [#41]	T	130.0/184.7
	1590004750	S.TRA LMUN5213T1G <SLVJ> [#42]		
	1590004750	S.TRA LMUN5213T1G <SLVJ> [#46]		
	1590004750	S.TRA LMUN5213T1G <SLVJ> [#47]		
	1590004750	S.TRA LMUN5213T1G <SLVJ> [#50]		
Q10	1530002691	S.TRA 2SC4116-GR(TE85RF) [#41]	T	141.0/181.1
	1530002691	S.TRA 2SC4116-GR(TE85RF) [#42]		
	1530002691	S.TRA 2SC4116-GR(TE85RF) [#46]		
	1530002691	S.TRA 2SC4116-GR(TE85RF) [#47]		
	1530002691	S.TRA 2SC4116-GR(TE85RF) [#50]		
Q11	1530002691	S.TRA 2SC4116-GR(TE85RF)	T	48.7/127.1
D1	1750002150	S.DIO DB2J31400L	T	41.1/91.0
D2	1790000450	S.DIO MA862(TX)	T	38.8/69.1
D5	1790000491	S.DIO HSM88ASTR-E	T	46.0/58.3
D7	1750002150	S.DIO DB2J31400L	T	37.7/62.7
D8	1750002150	S.DIO DB2J31400L	T	39.6/62.7
D9	1750000271	S.DIO 1SS301(TE85LF)	T	27.5/36.3
D11	1750002150	S.DIO DB2J31400L	T	30.9/26.1
D12	1750002150	S.DIO DB2J31400L	T	30.9/28.0
D13	1750002150	S.DIO DB2J31400L	T	33.4/18.8
D14	1750002150	S.DIO DB2J31400L	T	31.5/18.8
D16	1750000271	S.DIO 1SS301(TE85LF)	T	107.3/91.4
D17	1750000271	S.DIO 1SS301(TE85LF)	T	102.0/8.3
D21	1750002020	S.DIO DA2S10100L [#41]	T	42.1/177.4
	1750002020	S.DIO DA2S10100L [#42]		
	1750002020	S.DIO DA2S10100L [#46]		
	1750002020	S.DIO DA2S10100L [#47]		
	1750002020	S.DIO DA2S10100L [#50]		
D22	1750002020	S.DIO DA2S10100L	T	34.1/176.3
D24	1750002020	S.DIO DA2S10100L [#41]	T	147.1/183.1
	1750002020	S.DIO DA2S10100L [#42]		
	1750002020	S.DIO DA2S10100L [#46]		
	1750002020	S.DIO DA2S10100L [#47]		
	1750002020	S.DIO DA2S10100L [#50]		
D25	1750001970	S.ZEN DZ2J082M0L [#41]	T	145.2/181.3
	1750001970	S.ZEN DZ2J082M0L [#42]		
	1750001970	S.ZEN DZ2J082M0L [#46]		
	1750001970	S.ZEN DZ2J082M0L [#47]		
	1750001970	S.ZEN DZ2J082M0L [#50]		
D29	1750002020	S.DIO DA2S10100L [#41]	T	114.6/176.9
	1750002020	S.DIO DA2S10100L [#42]		
	1750002020	S.DIO DA2S10100L [#46]		
	1750002020	S.DIO DA2S10100L [#47]		
	1750002020	S.DIO DA2S10100L [#50]		
D30	1750002020	S.DIO DA2S10100L [#41]	T	114.6/175.6
	1750002020	S.DIO DA2S10100L [#42]		
	1750002020	S.DIO DA2S10100L [#46]		
	1750002020	S.DIO DA2S10100L [#47]		
	1750002020	S.DIO DA2S10100L [#50]		

Eqv.= This component is equivalent to the REF No. component listed above, and may be substituted on parts orders and repairs.

M.=Mounted side (T: Mounted on the Top side, B: Mounted on the Bottom side)  
S.=Surface mount

[TUNER-1 UNIT]

REF NO.	PARTS NO.	DESCRIPTION	M.	H/V LOCATION
D31	1750002020	S.DIO DA2S10100L	[#41]	T 114.6/174.3
	1750002020	S.DIO DA2S10100L	[#42]	
	1750002020	S.DIO DA2S10100L	[#46]	
	1750002020	S.DIO DA2S10100L	[#47]	
D32	1750002020	S.DIO DA2S10100L	[#41]	T 114.6/173.0
	1750002020	S.DIO DA2S10100L	[#42]	
	1750002020	S.DIO DA2S10100L	[#46]	
	1750002020	S.DIO DA2S10100L	[#47]	
D33	1750002020	S.DIO DA2S10100L	[#41]	T 114.7/163.0
	1750002020	S.DIO DA2S10100L	[#42]	
	1750002020	S.DIO DA2S10100L	[#46]	
	1750002020	S.DIO DA2S10100L	[#47]	
D34	1750002020	S.DIO DA2S10100L	[#41]	T 114.7/161.7
	1750002020	S.DIO DA2S10100L	[#42]	
	1750002020	S.DIO DA2S10100L	[#46]	
	1750002020	S.DIO DA2S10100L	[#47]	
D35	1750002020	S.DIO DA2S10100L	[#41]	T 114.7/160.4
	1750002020	S.DIO DA2S10100L	[#42]	
	1750002020	S.DIO DA2S10100L	[#46]	
	1750002020	S.DIO DA2S10100L	[#47]	
D36	1750002020	S.DIO DA2S10100L	[#41]	T 114.7/159.1
	1750002020	S.DIO DA2S10100L	[#42]	
	1750002020	S.DIO DA2S10100L	[#46]	
	1750002020	S.DIO DA2S10100L	[#47]	
D37	1750002020	S.DIO DA2S10100L	[#41]	T 114.7/157.8
	1750002020	S.DIO DA2S10100L	[#42]	
	1750002020	S.DIO DA2S10100L	[#46]	
	1750002020	S.DIO DA2S10100L	[#47]	
D38	1750002020	S.DIO DA2S10100L	[#41]	T 114.7/156.5
	1750002020	S.DIO DA2S10100L	[#42]	
	1750002020	S.DIO DA2S10100L	[#46]	
	1750002020	S.DIO DA2S10100L	[#47]	
D39	1750002020	S.DIO DA2S10100L	[#41]	T 114.7/148.4
	1750002020	S.DIO DA2S10100L	[#42]	
	1750002020	S.DIO DA2S10100L	[#46]	
	1750002020	S.DIO DA2S10100L	[#47]	
D40	1750002020	S.DIO DA2S10100L	[#41]	T 114.7/147.1
	1750002020	S.DIO DA2S10100L	[#42]	
	1750002020	S.DIO DA2S10100L	[#46]	
	1750002020	S.DIO DA2S10100L	[#47]	
D41	1750002020	S.DIO DA2S10100L	[#41]	T 114.7/145.8
	1750002020	S.DIO DA2S10100L	[#42]	
	1750002020	S.DIO DA2S10100L	[#46]	
	1750002020	S.DIO DA2S10100L	[#47]	
D42	1750002020	S.DIO DA2S10100L	[#41]	T 114.7/144.5
	1750002020	S.DIO DA2S10100L	[#42]	
	1750002020	S.DIO DA2S10100L	[#46]	
	1750002020	S.DIO DA2S10100L	[#47]	
D43	1750002020	S.DIO DA2S10100L	[#41]	T 114.7/143.2
	1750002020	S.DIO DA2S10100L	[#42]	
	1750002020	S.DIO DA2S10100L	[#46]	
	1750002020	S.DIO DA2S10100L	[#47]	
D44	1750002020	S.DIO DA2S10100L	[#41]	T 114.7/135.4
	1750002020	S.DIO DA2S10100L	[#42]	
	1750002020	S.DIO DA2S10100L	[#46]	
	1750002020	S.DIO DA2S10100L	[#47]	
D45	1750002020	S.DIO DA2S10100L	[#41]	T 114.7/134.1
	1750002020	S.DIO DA2S10100L	[#42]	
	1750002020	S.DIO DA2S10100L	[#46]	
	1750002020	S.DIO DA2S10100L	[#47]	
D46	1750002020	S.DIO DA2S10100L	[#41]	T 114.7/132.8
	1750002020	S.DIO DA2S10100L	[#42]	
	1750002020	S.DIO DA2S10100L	[#46]	
	1750002020	S.DIO DA2S10100L	[#47]	
D47	1750002020	S.DIO DA2S10100L	[#41]	T 114.7/131.5
	1750002020	S.DIO DA2S10100L	[#42]	
	1750002020	S.DIO DA2S10100L	[#46]	
	1750002020	S.DIO DA2S10100L	[#47]	
D48	1750002020	S.DIO DA2S10100L	[#41]	T 114.7/130.2
	1750002020	S.DIO DA2S10100L	[#42]	
	1750002020	S.DIO DA2S10100L	[#46]	
	1750002020	S.DIO DA2S10100L	[#47]	
D49	1750002020	S.DIO DA2S10100L	[#41]	T 114.7/128.9
	1750002020	S.DIO DA2S10100L	[#42]	
	1750002020	S.DIO DA2S10100L	[#46]	
	1750002020	S.DIO DA2S10100L	[#47]	
D50	1750002020	S.DIO DA2S10100L	[#41]	T 114.7/127.6
	1750002020	S.DIO DA2S10100L	[#42]	
	1750002020	S.DIO DA2S10100L	[#46]	
	1750002020	S.DIO DA2S10100L	[#47]	

Eqv.= This component is equivalent to the REF No. component listed above, and may be substituted on parts orders and repairs.

[TUNER-1 UNIT]

REF NO.	PARTS NO.	DESCRIPTION	M.	H/V LOCATION
D51	1750002020	S.DIO DA2S10100L	[#41]	T 114.7/126.3
	1750002020	S.DIO DA2S10100L	[#42]	
	1750002020	S.DIO DA2S10100L	[#46]	
	1750002020	S.DIO DA2S10100L	[#47]	
	1750002020	S.DIO DA2S10100L	[#50]	
D52	1750000271	S.DIO 1SS301(TE85LF)		T 98.5/30.2
D53	1750000271	S.DIO 1SS301(TE85LF)		T 252.4/58.2
D54	1750000271	S.DIO 1SS301(TE85LF)		T 113.0/39.9
D55	1750000271	S.DIO 1SS301(TE85LF)		T 127.6/36.6
D56	1750000271	S.DIO 1SS301(TE85LF)		T 142.7/41.6
D57	1750000271	S.DIO 1SS301(TE85LF)		T 157.1/42.5
D58	1750000271	S.DIO 1SS301(TE85LF)		T 167.7/43.1
D59	1750000271	S.DIO 1SS301(TE85LF)		T 185.0/35.1
D60	1750000271	S.DIO 1SS301(TE85LF)		T 199.4/37.6
D61	1750000271	S.DIO 1SS301(TE85LF)		T 231.7/56.6
D62	1750000271	S.DIO 1SS301(TE85LF)		T 253.4/53.5
D63	1750000271	S.DIO 1SS301(TE85LF)		T 272.4/37.0
D64	1750000271	S.DIO 1SS301(TE85LF)		T 275.0/37.0
D65	1750000271	S.DIO 1SS301(TE85LF)		T 113.0/90.0
D66	1750000271	S.DIO 1SS301(TE85LF)		T 131.1/90.2
D67	1750000271	S.DIO 1SS301(TE85LF)		T 143.8/90.3
D68	1750000271	S.DIO 1SS301(TE85LF)		T 156.8/90.2
D69	1750000271	S.DIO 1SS301(TE85LF)		T 169.4/90.2
D70	1750000271	S.DIO 1SS301(TE85LF)		T 181.7/90.2
D71	1750000271	S.DIO 1SS301(TE85LF)		T 194.0/90.4
D72	1750000271	S.DIO 1SS301(TE85LF)		T 206.6/90.2
D73	1750000271	S.DIO 1SS301(TE85LF)		T 218.8/90.3
D74	1750000271	S.DIO 1SS301(TE85LF)		T 193.3/136.3
D75	1750000271	S.DIO 1SS301(TE85LF)		T 193.4/156.3
D76	1750000271	S.DIO 1SS301(TE85LF)		T 193.3/176.7
D77	1790000491	S.DIO HSM88ASTR-E		T 36.1/41.8
D78	1750002020	S.DIO DA2S10100L		T 25.0/171.7
D79	1750002020	S.DIO DA2S10100L		T 43.4/126.9
D80	1790000491	S.DIO HSM88ASTR-E		T 155.0/179.4
D81	1750000431	S.DIO HSB88WSTR-E		T 44.4/42.4
D85	1750000271	S.DIO 1SS301(TE85LF)		T 27.7/72.7
D86	1750002150	S.DIO DB2J31400L	[#43]	T 210.2/188.2
	1750002150	S.DIO DB2J31400L	[#44]	
	1750002150	S.DIO DB2J31400L	[#48]	
D86	1750002150	S.DIO DB2J31400L	[#49]	T 210.2/188.2
	1750002150	S.DIO DB2J31400L	[#48]	
	1750002150	S.DIO DB2J31400L	[#49]	
X1	6050009870	S.XTA CR-567 SMD-49 9.8304 MHz <KDS>		T 26.6/143.7
L1	6140003490	COI LR-391 (TR10X5X5 3A6)		
L2	6140000930	COI LR-116		
L3	6140000930	COI LR-116		
L4	6140000070	COI LR-19		
L5	6200011630	S.COI NL565050T-222J-PF		T 47.0/20.0
L6	6110002750	COI LA-459		
L7	6110002760	COI LA-460		
L8	6110002770	COI LA-461		
L9	6110002780	COI LA-462		
L10	6110002790	COI LA-463		
L11	6110002800	COI LA-464		
L12	6110002810	COI LA-465		
L13	6110002820	COI LA-466		
L14	6110002830	COI LA-467		
L15	6110002840	COI LA-468		
L16	6110002850	COI LA-469		
L17	6110002860	COI LA-470		
L18	6200003261	S.COI NLV32T-101J		T 23.1/126.2
L19	6200003950	S.COI HF50ACC 322513-T	Only	T 187.6/169.2
L20	6200008820	S.COI HF70ACC 635050-T		T 196.8/190.0
L22	6200008820	S.COI HF70ACC 635050-T		T 177.7/166.0
L24	6200003261	S.COI NLV32T-101J		T 167.6/167.7
L25	6200003261	S.COI NLV32T-101J		T 157.6/184.0
L28	6200003261	S.COI NLV32T-101J		T 25.3/69.0
L31	6200011610	S.COI NLC453232T-100K-PF		T 238.8/60.8
L32	6200001831	S.COI NLV32T-100J		T 111.2/95.0
L33	6200011620	S.COI NLC453232T-470K-PF		T 75.3/179.8
L34	6200008820	S.COI HF70ACC 635050-T		T 10.3/134.7
L35	6140001550	COI LR-174	[#43]	T 205.3/192.3
	6140001550	COI LR-174	[#44]	
	6140001550	COI LR-174	[#48]	
L36	6140001550	COI LR-174	[#49]	T 205.4/188.8
	6200003950	S.COI HF50ACC 322513-T	[#43]	
	6200003950	S.COI HF50ACC 322513-T	[#44]	
L37	6200003950	S.COI HF50ACC 322513-T	[#48]	T 205.4/188.8
	6200003950	S.COI HF50ACC 322513-T	[#49]	
	6200003950	S.COI HF50ACC 322513-T	[#43]	
L37	6200003950	S.COI HF50ACC 322513-T	[#44]	T 205.4/188.8
	6200003950	S.COI HF50ACC 322513-T	[#48]	
	6200003950	S.COI HF50ACC 322513-T	[#49]	
R1	7030003440	S.RES ERJ3GEYJ 102 V (1K)		T 44.9/68.5
R2	7030007190	S.RES ERJ12YJ220U (22)		T 44.3/79.1
R3	7030007190	S.RES ERJ12YJ220U (22)		T 50.5/79.1
R8	7030003560	S.RES ERJ3GEYJ 103 V (10K)		T 40.6/95.1
R9	7030003590	S.RES ERJ3GEYJ 183 V (18K)		T 36.9/72.1
R10	7030003640	S.RES ERJ3GEYJ 473 V (47K)		T 34.6/72.8
R11	7030003480	S.RES ERJ3GEYJ 222 V (2.2K)		T 36.1/47.7
R12	7030003520	S.RES ERJ3GEYJ 472 V (4.7K)		T 28.3/50.7
R13	7030006270	S.RES ERJ12YJ221U (220)		T 25.8/63.6
R14	7030003200	S.RES ERJ3GEYJ 100 V (10)		T 43.4/58.2
R15	7030003560	S.RES ERJ3GEYJ 103 V (10K)		T 36.1/44.9
R16	7070000731	RES ERG2SJ 331 (330)		
R17	7070000731	RES ERG2SJ 331 (330)		
R18	7070000721	RES ERG2SJ 271 (270)		
R19	7070000291	RES ERG2SJ 221 (220)		
R20	7070000291	RES ERG2SJ 221 (220)		
R21	7070000291	RES ERG2SJ 221 (220)		

M.=Mounted side (T: Mounted on the Top side, B: Mounted on the Bottom side) S.=Surface mount



[TUNER-1 UNIT]

REF NO.	PARTS NO.	DESCRIPTION	M.	H/V LOCATION
R22	7030011300	S.RES ERJ1TY 331U (330)	T	80.8/45.6
R23	7030011300	S.RES ERJ1TY 331U (330)	T	80.8/49.4
R24	7030011310	S.RES ERJ1TY 271U (270)	T	80.8/53.2
R25	7030003640	S.RES ERJ3GEYJ 473 V (47K)	T	37.6/58.6
R26	7030003640	S.RES ERJ3GEYJ 473 V (47K)	T	33.2/38.4
R27	7030003480	S.RES ERJ3GEYJ 222 V (2.2K)	T	33.4/30.1
R28	7030006220	S.RES ERJ12YJ470U (47)	T	78.4/36.9
R29	7030006220	S.RES ERJ12YJ470U (47)	T	66.7/36.3
R30	7030006220	S.RES ERJ12YJ470U (47)	T	66.7/32.1
R31	7030006220	S.RES ERJ12YJ470U (47)	T	56.3/13.7
R32	7030003280	S.RES ERJ3GEYJ 470 V (47)	T	42.9/27.9
R33	7030003720	S.RES ERJ3GEYJ 224 V (220K)	T	38.0/50.3
R34	7030003720	S.RES ERJ3GEYJ 224 V (220K)	T	31.6/42.8
R35	7030003650	S.RES ERJ3GEYJ 563 V (56K)	T	28.2/30.1
R36	7030003480	S.RES ERJ3GEYJ 222 V (2.2K)	T	27.5/19.9
R37	7030003640	S.RES ERJ3GEYJ 473 V (47K)	T	23.8/19.2
R38	7030003440	S.RES ERJ3GEYJ 102 V (1K)	T	37.7/28.5
R39	7030003560	S.RES ERJ3GEYJ 103 V (10K)	T	38.0/20.9
R40	7030003560	S.RES ERJ3GEYJ 103 V (10K)	T	39.5/20.9
R41	7030003560	S.RES ERJ3GEYJ 103 V (10K)	T	36.2/20.8
R42	7030003440	S.RES ERJ3GEYJ 102 V (1K)	T	38.5/26.1
R43	7030007990	S.RES ERJ12YJ820U (82)	T	78.1/32.8
R44	7030003360	S.RES ERJ3GEYJ 221 V (220)	T	41.3/20.8
R45	7540000250	ABS SA05C 401N		
R46	7030007980	S.RES ERJ12YJ473U (47K)	T	83.8/31.0
R51	7030007240	S.RES ERJ12YJ680U (68)	T	103.1/85.0
R52	7030007240	S.RES ERJ12YJ680U (68)	T	103.5/20.6
R53	7030003640	S.RES ERJ3GEYJ 473 V (47K)	T	34.5/68.8
R54	7030003370	S.RES ERJ3GEYJ 271 V (270)	T	29.2/67.1
R55	7030010610	S.RES ERJ1TYJ 470U (47)	T	12.5/176.4
R56	7030003600	S.RES ERJ3GEYJ 223 V (22K)	T	151.6/180.6
R57	7030003680	S.RES ERJ3GEYJ 104 V (100K)	T	25.7/180.8
R58	7030003500	S.RES ERJ3GEYJ 332 V (3.3K)	T	37.7/170.0
R59	7030003580	S.RES ERJ3GEYJ 153 V (15K)	T	37.7/171.4
R60	7030003480	S.RES ERJ3GEYJ 222 V (2.2K)	[#41] T	130.1/189.3
	7030003480	S.RES ERJ3GEYJ 222 V (2.2K)	[#42]	
	7030003480	S.RES ERJ3GEYJ 222 V (2.2K)	[#46]	
	7030003480	S.RES ERJ3GEYJ 222 V (2.2K)	[#47]	
	7030003480	S.RES ERJ3GEYJ 222 V (2.2K)	[#50]	
R61	7030003530	S.RES ERJ3GEYJ 562 V (5.6K)	[#41] T	136.9/183.9
	7030003530	S.RES ERJ3GEYJ 562 V (5.6K)	[#42]	
	7030003530	S.RES ERJ3GEYJ 562 V (5.6K)	[#46]	
	7030003530	S.RES ERJ3GEYJ 562 V (5.6K)	[#47]	
	7030003530	S.RES ERJ3GEYJ 562 V (5.6K)	[#50]	
R62	7030003360	S.RES ERJ3GEYJ 221 V (220)	[#41] T	135.3/181.2
	7030003360	S.RES ERJ3GEYJ 221 V (220)	[#42]	
	7030003360	S.RES ERJ3GEYJ 221 V (220)	[#46]	
	7030003360	S.RES ERJ3GEYJ 221 V (220)	[#47]	
	7030003360	S.RES ERJ3GEYJ 221 V (220)	[#50]	
R63	7030003430	S.RES ERJ3GEYJ 821 V (820)	[#41] T	143.3/181.4
	7030003430	S.RES ERJ3GEYJ 821 V (820)	[#42]	
	7030003430	S.RES ERJ3GEYJ 821 V (820)	[#46]	
	7030003430	S.RES ERJ3GEYJ 821 V (820)	[#47]	
	7030003430	S.RES ERJ3GEYJ 821 V (820)	[#50]	
R64	7030003640	S.RES ERJ3GEYJ 473 V (47K)	[#41] T	138.6/183.9
	7030003640	S.RES ERJ3GEYJ 473 V (47K)	[#42]	
	7030003640	S.RES ERJ3GEYJ 473 V (47K)	[#46]	
	7030003640	S.RES ERJ3GEYJ 473 V (47K)	[#47]	
	7030003640	S.RES ERJ3GEYJ 473 V (47K)	[#50]	
R66	7030003680	S.RES ERJ3GEYJ 104 V (100K)	T	25.0/174.9
R67	7030003640	S.RES ERJ3GEYJ 473 V (47K)	T	25.4/126.3
R68	7030005521	S.RES ERA3YKD 334V (330K)	[#41] T	40.7/176.1
	7030005521	S.RES ERA3YKD 334V (330K)	[#42]	
	7030005521	S.RES ERA3YKD 334V (330K)	[#46]	
	7030005521	S.RES ERA3YKD 334V (330K)	[#47]	
	7030005521	S.RES ERA3YKD 334V (330K)	[#50]	
R71	7030003440	S.RES ERJ3GEYJ 102 V (1K)	T	24.4/163.8
R72	7030003440	S.RES ERJ3GEYJ 102 V (1K)	T	24.4/162.4
R73	7030003440	S.RES ERJ3GEYJ 102 V (1K)	T	33.7/138.9
R74	7030003440	S.RES ERJ3GEYJ 102 V (1K)	T	33.7/137.6
R76	7030003680	S.RES ERJ3GEYJ 104 V (100K)	T	48.0/129.6
R77	7030003720	S.RES ERJ3GEYJ 224 V (220K)	T	46.4/129.6
R78	7030005631	S.RES ERA3YKD 154V (150K)	T	44.9/126.9
R84	7030003400	S.RES ERJ3GEYJ 471 V (470)	T	80.2/174.0
R85	7030003400	S.RES ERJ3GEYJ 471 V (470)	T	80.2/171.7
R86	7030003400	S.RES ERJ3GEYJ 471 V (470)	T	80.2/169.4
R87	7030003400	S.RES ERJ3GEYJ 471 V (470)	T	80.2/167.1
R88	7030003400	S.RES ERJ3GEYJ 471 V (470)	T	80.2/164.8
R89	7030003400	S.RES ERJ3GEYJ 471 V (470)	T	80.2/162.5
R90	7030003400	S.RES ERJ3GEYJ 471 V (470)	T	80.2/160.2
R92	7030003400	S.RES ERJ3GEYJ 471 V (470)	T	80.2/157.9
R93	7030003400	S.RES ERJ3GEYJ 471 V (470)	T	80.2/155.6
R94	7030003400	S.RES ERJ3GEYJ 471 V (470)	T	80.2/153.3
R95	7030003400	S.RES ERJ3GEYJ 471 V (470)	T	80.2/151.0
R96	7030003400	S.RES ERJ3GEYJ 471 V (470)	T	80.2/148.7
R97	7030003400	S.RES ERJ3GEYJ 471 V (470)	T	80.2/146.4
R98	7030003400	S.RES ERJ3GEYJ 471 V (470)	T	80.2/144.1
R99	7030003400	S.RES ERJ3GEYJ 471 V (470)	T	80.2/141.8
R101	7030003400	S.RES ERJ3GEYJ 471 V (470)	T	80.2/139.5
R102	7030003400	S.RES ERJ3GEYJ 471 V (470)	T	80.2/137.2
R103	7030003400	S.RES ERJ3GEYJ 471 V (470)	T	80.2/134.9
R104	7030003400	S.RES ERJ3GEYJ 471 V (470)	T	80.2/132.6
R105	7030003400	S.RES ERJ3GEYJ 471 V (470)	T	80.2/130.3
R106	7030003400	S.RES ERJ3GEYJ 471 V (470)	T	80.2/128.0
R107	7030003400	S.RES ERJ3GEYJ 471 V (470)	T	80.2/125.7
R108	7030003400	S.RES ERJ3GEYJ 471 V (470)	T	80.2/123.4
R109	7030003240	S.RES ERJ3GEYJ 220 V (22)	T	105.0/34.4
R110	7030003240	S.RES ERJ3GEYJ 220 V (22)	T	119.9/33.0
R111	7030003240	S.RES ERJ3GEYJ 220 V (22)	T	134.9/38.0
R112	7030003240	S.RES ERJ3GEYJ 220 V (22)	T	149.9/39.0
R113	7030003240	S.RES ERJ3GEYJ 220 V (22)	T	167.6/41.0
R114	7030003240	S.RES ERJ3GEYJ 220 V (22)	T	182.2/33.8
R115	7030003240	S.RES ERJ3GEYJ 220 V (22)	T	199.3/34.0
R116	7030003240	S.RES ERJ3GEYJ 220 V (22)	T	234.2/53.0
R117	7030003240	S.RES ERJ3GEYJ 220 V (22)	T	258.7/49.1

Eqv.= This component is equivalent to the REF No. component listed above, and may be substituted on parts orders and repairs.

[TUNER-1 UNIT]

REF NO.	PARTS NO.	DESCRIPTION	M.	H/V LOCATION
R118	7030003240	S.RES ERJ3GEYJ 220 V (22)	T	274.8/31.7
R119	7030003240	S.RES ERJ3GEYJ 220 V (22)	T	262.6/32.7
R120	7030010620	S.RES ERJ12YJ180U (18)	T	192.5/130.3
R121	7030010620	S.RES ERJ12YJ180U (18)	T	192.5/149.9
R122	7030003240	S.RES ERJ3GEYJ 220 V (22)	T	98.5/32.4
R123	7030003240	S.RES ERJ3GEYJ 220 V (22)	T	105.7/87.8
R124	7030003240	S.RES ERJ3GEYJ 220 V (22)	T	126.4/89.6
R125	7030003240	S.RES ERJ3GEYJ 220 V (22)	T	138.9/89.6
R126	7030003240	S.RES ERJ3GEYJ 220 V (22)	T	151.4/89.6
R127	7030003240	S.RES ERJ3GEYJ 220 V (22)	T	163.9/89.6
R128	7030003240	S.RES ERJ3GEYJ 220 V (22)	T	176.4/89.6
R129	7030003240	S.RES ERJ3GEYJ 220 V (22)	T	188.9/89.6
R130	7030003240	S.RES ERJ3GEYJ 220 V (22)	T	201.5/89.6
R131	7030003240	S.RES ERJ3GEYJ 220 V (22)	T	213.5/89.8
R132	7030010620	S.RES ERJ12YJ180U (18)	T	241.0/66.8
R133	7030010620	S.RES ERJ12YJ180U (18)	T	192.5/162.1
R149	7030003400	S.RES ERJ3GEYJ 471 V (470)	T	80.2/173.0
R150	7030003520	S.RES ERJ3GEYJ 472 V (4.7K)	T	24.5/51.0
R151	7030003480	S.RES ERJ3GEYJ 222 V (2.2K)	T	39.6/59.4
R156	7030003640	S.RES ERJ3GEYJ 473 V (47K)	T	133.3/183.1
R157	7030005521	S.RES ERA3YKD 334V (330K)	T	34.9/174.0
R158	7030003490	S.RES ERJ3GEYJ 272 V (2.7K)	[#41] T	136.9/181.2
	7030003490	S.RES ERJ3GEYJ 272 V (2.7K)	[#42]	
	7030003490	S.RES ERJ3GEYJ 272 V (2.7K)	[#46]	
	7030003490	S.RES ERJ3GEYJ 272 V (2.7K)	[#47]	
	7030003490	S.RES ERJ3GEYJ 272 V (2.7K)	[#50]	
R159	7030003560	S.RES ERJ3GEYJ 103 V (10K)	T	67.2/159.5
R160	7030003400	S.RES ERJ3GEYJ 471 V (470)	T	69.2/159.1
R162	7030003640	S.RES ERJ3GEYJ 473 V (47K)	T	31.3/165.8
R163	7030003680	S.RES ERJ3GEYJ 104 V (100K)	T	38.4/124.4
R167	7030003520	S.RES ERJ3GEYJ 472 V (4.7K)	T	167.7/125.9
R168	7030003520	S.RES ERJ3GEYJ 472 V (4.7K)	T	165.9/121.3
R169	7030003520	S.RES ERJ3GEYJ 472 V (4.7K)	T	164.3/125.7
R170	7030003520	S.RES ERJ3GEYJ 472 V (4.7K)	T	162.4/121.3
R171	7030003520	S.RES ERJ3GEYJ 472 V (4.7K)	T	160.7/125.8
R172	7030003520	S.RES ERJ3GEYJ 472 V (4.7K)	T	158.9/121.3
R173	7030003520	S.RES ERJ3GEYJ 472 V (4.7K)	T	157.0/125.9
R174	7030003520	S.RES ERJ3GEYJ 472 V (4.7K)	T	155.4/121.3
R175	7030003520	S.RES ERJ3GEYJ 472 V (4.7K)	T	153.7/125.8
R176	7030003520	S.RES ERJ3GEYJ 472 V (4.7K)	T	151.9/121.4
R177	7030003520	S.RES ERJ3GEYJ 472 V (4.7K)	T	150.2/125.8
R178	7030003520	S.RES ERJ3GEYJ 472 V (4.7K)	T	148.4/121.4
R179	7030003520	S.RES ERJ3GEYJ 472 V (4.7K)	T	167.0/152.4
R180	7030003520	S.RES ERJ3GEYJ 472 V (4.7K)	T	164.0/156.3
R181	7030003520	S.RES ERJ3GEYJ 472 V (4.7K)	T	148.4/152.4
R182	7030003520	S.RES ERJ3GEYJ 472 V (4.7K)	T	150.2/156.3
R183	7030003520	S.RES ERJ3GEYJ 472 V (4.7K)	T	151.9/152.5
R184	7030003520	S.RES ERJ3GEYJ 472 V (4.7K)	T	153.6/156.3
R185	7030003520	S.RES ERJ3GEYJ 472 V (4.7K)	T	155.3/152.5
R186	7030003520	S.RES ERJ3GEYJ 472 V (4.7K)	T	157.1/156.3
R187	7030003520	S.RES ERJ3GEYJ 472 V (4.7K)	T	158.9/152.5
R188	7030003520	S.RES ERJ3GEYJ 472 V (4.7K)	T	160.6/156.3
R189	7030003520	S.RES ERJ3GEYJ 472 V (4.7K)	T	162.5/152.5
R190	7030006070	S.RES ERJ12YJ101U (100)	T	77.6/28.9
R191	7030003480	S.RES ERJ3GEYJ 222 V (2.2K)	T	26.4/33.0
R192	7030003550	S.RES ERJ3GEYJ 822 V (8.2K)	T	29.6/36.3
R193	7030003740	S.RES ERJ3GEYJ 334 V (330K)	T	28.3/49.2
R194	7310005540	S.TRI TMC3ADC14X (10K)	T	32.5/51.1
R195	7030003440	S.RES ERJ3GEYJ 102 V (1K)	T	24.7/71.9
R196	7030003560	S.RES ERJ3GEYJ 562 V (5.6K)	T	30.8/71.9
R198	7030003650	S.RES ERJ3GEYJ 563 V (56K)	T	131.6/189.4
R200	7030003680	S.RES ERJ3GEYJ 104 V (100K)	T	24.9/173.3
R201	7030003440	S.RES ERJ3GEYJ 102 V (1K)	T	33.7/135.1
R202	7030003720	S.RES ERJ3GEYJ 224 V (220K)	T	46.4/126.9
R203	7030003640	S.RES ERJ3GEYJ 473 V (47K)	T	25.0/176.3
R204	7030003640	S.RES ERJ3GEYJ 473 V (47K)	T	23.1/178.5
R205	7410001290	ARR RKL3BD 104J		
R206	7410001290	ARR RKL3BD 104J		
R207	7410001290	ARR RKL3BD 104J		
R208	7410001290	ARR RKL3BD 104J		
R209	7410001290	ARR RKL3BD 104J		
R210	7030003480	S.RES ERJ3GEYJ 222 V (2.2K)	T	72.0/123.4
R211	7030003480	S.RES ERJ3GEYJ 222 V (2.2K)	T	72.0/125.7
R212	7030003480	S.RES ERJ3GEYJ 222 V (2.2K)	T	72.0/128.0
R213	7030003480	S.RES ERJ3GEYJ 222 V (2.2K)	T	72.0/130.3
R214	7030003480	S.RES ERJ3GEYJ 222 V (2.2K)	T	72.0/132.6

[TUNER-1 UNIT]

REF NO.	PARTS NO.	DESCRIPTION	M.	H/V LOCATION
R244	7030003860	S.RES ERJ3GE JPW V	[#43] T	27.9/152.6
	7030003860	S.RES ERJ3GE JPW V	[#44]	
	7030003860	S.RES ERJ3GE JPW V	[#46]	
	7030003860	S.RES ERJ3GE JPW V	[#48]	
	7030003860	S.RES ERJ3GE JPW V	[#49]	
	7030003860	S.RES ERJ3GE JPW V	[#50]	
R248	7030003640	S.RES ERJ3GEYJ 473 V (47K)	T	40.5/165.5
R249	7030003640	S.RES ERJ3GEYJ 473 V (47K)	T	40.5/162.9
R250	7030003640	S.RES ERJ3GEYJ 473 V (47K)	T	40.5/164.2
R251	7030003640	S.RES ERJ3GEYJ 473 V (47K)	T	47.7/157.5
R252	7030003640	S.RES ERJ3GEYJ 473 V (47K)	T	34.7/162.4
R253	7030005521	S.RES ERA3YKD 334V (330K)	T	34.2/170.7
R254	7030007911	S.RES ERA3YKD 563V (56K)	[#41] T	43.5/176.1
	7030007911	S.RES ERA3YKD 563V (56K)	[#42]	
	7030007911	S.RES ERA3YKD 563V (56K)	[#46]	
	7030007911	S.RES ERA3YKD 563V (56K)	[#47]	
	7030007911	S.RES ERA3YKD 563V (56K)	[#50]	
R255	7030010610	S.RES ERJ1TYJ 470U (47)	T	12.5/171.9
R256	7030003860	S.RES ERJ3GE JPW V	[#43] T	67.5/178.5
	7030003860	S.RES ERJ3GE JPW V	[#44]	
	7030003860	S.RES ERJ3GE JPW V	[#48]	
	7030003860	S.RES ERJ3GE JPW V	[#49]	
R257	7030003860	S.RES ERJ3GE JPW V	[#43] T	42.3/170.0
	7030003860	S.RES ERJ3GE JPW V	[#44]	
	7030003860	S.RES ERJ3GE JPW V	[#48]	
	7030003860	S.RES ERJ3GE JPW V	[#49]	
R258	7030010520	S.RES ERJ1TYJ 101U (100)	[#43] T	217.4/191.1
	7030010520	S.RES ERJ1TYJ 101U (100)	[#44]	
	7030010520	S.RES ERJ1TYJ 101U (100)	[#48]	
	7030010520	S.RES ERJ1TYJ 101U (100)	[#49]	
R259	7030003620	S.RES ERJ3GEYJ 333 V (33K)	[#43] T	209.3/190.4
	7030003620	S.RES ERJ3GEYJ 333 V (33K)	[#44]	
	7030003620	S.RES ERJ3GEYJ 333 V (33K)	[#48]	
	7030003620	S.RES ERJ3GEYJ 333 V (33K)	[#49]	
R262	7030010520	S.RES ERJ1TYJ 101U (100)	[#43] T	213.7/191.1
	7030010520	S.RES ERJ1TYJ 101U (100)	[#44]	
	7030010520	S.RES ERJ1TYJ 101U (100)	[#48]	
	7030010520	S.RES ERJ1TYJ 101U (100)	[#49]	
R263	7030010520	S.RES ERJ1TYJ 101U (100)	[#43] T	221.1/191.1
	7030010520	S.RES ERJ1TYJ 101U (100)	[#44]	
	7030010520	S.RES ERJ1TYJ 101U (100)	[#48]	
	7030010520	S.RES ERJ1TYJ 101U (100)	[#49]	
C1	4030006880	S.CER C1608 JB 1H 472K-T	T	42.2/68.5
C2	4030011120	S.CER GRM31M2C2H100JV01L (GRM42-6)	T	44.7/95.5
C3	4030007170	S.CER C1608 CH 1H 221J-T	T	40.6/93.7
C4	4030010760	S.CER C1608 CH 1H 331J-T	T	40.6/96.5
C6	4030011070	S.CER GRM31M2C2H5R0CY21L (GJRM42-6 CH)	T	49.3/60.9
C7	4540000130	S.TRI TZB4Z100AB10R00	T	44.8/65.1
C8	4030007160	S.CER C1608 CH 1H 181J-T	T	39.5/65.1
C9	4510008690	S.ELE EEE1EA330SP	T	26.3/56.0
C10	4030006880	S.CER C1608 JB 1H 472K-T	T	24.4/49.2
C11	4030005110	S.CER C2012 JB 1E 473K-T	T	51.1/48.7
C12	4030010760	S.CER C1608 CH 1H 331J-T	T	37.6/60.3
C13	4030010760	S.CER C1608 CH 1H 331J-T	T	33.4/27.3
C14	4030005110	S.CER C2012 JB 1E 473K-T	T	47.1/27.9
C15	4030006880	S.CER C1608 JB 1H 472K-T	T	30.1/38.4
C16	4030006880	S.CER C1608 JB 1H 472K-T	T	37.6/57.2
C17	4030011600	S.CER C1608 JB 1E 104K-T	T	30.6/30.1
C18	4030005110	S.CER C2012 JB 1E 473K-T	T	32.5/15.8
C19	4030007010	S.CER C1608 CH 1H 100D-T	T	59.5/21.5
C20	4030008560	S.CER C1608 CH 1H 300J-T	T	59.5/19.0
C21	4030010760	S.CER C1608 CH 1H 331J-T	T	29.8/19.1
C22	4030006880	S.CER C1608 JB 1H 472K-T	T	24.9/27.1
C23	4030005110	S.CER C2012 JB 1E 473K-T	T	38.6/24.3
C24	4320001230	S.MIC UC552H 1201J-T	T	108.6/64.5
C25	4320001230	S.MIC UC552H 1201J-T	T	108.6/58.0
C26	4320001230	S.MIC UC552H 1201J-T	T	121.5/61.9
C28	4010008720	CER DEA1X3D271JA2B	T	
C29	4010008710	CER DEA1X3D331JA3B	T	
C30	4010008560	CER DEA1X3F151JA3B (DE1107SL151J)	T	
C31	4010008560	CER DEA1X3F151JA3B (DE1107SL151J)	T	
C32	4010008560	CER DEA1X3F151JA3B (DE1107SL151J)	T	
C34	4030006880	S.CER C1608 JB 1H 472K-T	T	100.7/30.2
C35	4010008560	CER DEA1X3F151JA3B (DE1107SL151J)	T	
C36	4010008560	CER DEA1X3F151JA3B (DE1107SL151J)	T	
C37	4010004790	CER DEC1X3J680JC4B (DE1210SL680J)	T	
C38	4010008680	CER DEA1X3F820JA3B	T	
C39	4010004770	CER DEC1X3J390JC4B (DE0910SL390J)	T	
C40	4010004770	CER DEC1X3J390JC4B (DE0910SL390J)	T	
C41	4010008731	CER DEA1X3F180JCDB-Z	T	
C42	4010008731	CER DEA1X3F180JCDB-Z	T	
C43	4030006880	S.CER C1608 JB 1H 472K-T	T	105.0/92.5
C44	4010004810	CER DEC1X3J101JC4B (DE1310SL101J)	T	
C45	4010004810	CER DEC1X3J101JC4B (DE1310SL101J)	T	
C46	4010004810	CER DEC1X3J101JC4B (DE1310SL101J)	T	
C47	4010004810	CER DEC1X3J101JC4B (DE1310SL101J)	T	
C48	4030006880	S.CER C1608 JB 1H 472K-T	T	99.9/8.2
C50	4030008960	S.CER C2012 JB 1C 104K-T	T	36.1/69.0
C53	4510008570	S.ELE EEE1CA220SR	T	11.6/140.4

Eqv.= This component is equivalent to the REF No. component listed above, and may be substituted on parts orders and repairs.

[TUNER-1 UNIT]

REF NO.	PARTS NO.	DESCRIPTION	M.	H/V LOCATION
C54	4030006880	S.CER C1608 JB 1H 472K-T	T	10.1/145.3
C55	4030006880	S.CER C1608 JB 1H 472K-T	T	9.7/154.5
C56	4510008520	S.ELE EEE1CA470SP	T	12.3/158.7
C58	4030006880	S.CER C1608 JB 1H 472K-T	T	185.3/165.3
C59	4030005110	S.CER C2012 JB 1E 473K-T	T	185.4/163.3
C60	4510008510	S.ELE EEE1CA471P	T	176.5/157.3
C62	4030006880	S.CER C1608 JB 1H 472K-T	T	151.5/182.5
C64	4030006880	S.CER C1608 JB 1H 472K-T	T	151.6/184.0
C65	4030006880	S.CER C1608 JB 1H 472K-T	T	37.7/172.8
C66	4030006880	S.CER C1608 JB 1H 472K-T	[#41] T	130.8/187.2
	4030006880	S.CER C1608 JB 1H 472K-T	[#42]	
	4030006880	S.CER C1608 JB 1H 472K-T	[#46]	
	4030006880	S.CER C1608 JB 1H 472K-T	[#47]	
	4030006880	S.CER C1608 JB 1H 472K-T	[#50]	
C68	4030006880	S.CER C1608 JB 1H 472K-T	T	23.1/129.1
C69	4030006860	S.CER C1608 JB 1H 102K-T	[#41] T	148.8/183.1
	4030006860	S.CER C1608 JB 1H 102K-T	[#42]	
	4030006860	S.CER C1608 JB 1H 102K-T	[#46]	
	4030006860	S.CER C1608 JB 1H 102K-T	[#47]	
	4030006860	S.CER C1608 JB 1H 102K-T	[#50]	
C70	4030006880	S.CER C1608 JB 1H 472K-T	[#41] T	130.1/182.3
	4030006880	S.CER C1608 JB 1H 472K-T	[#42]	
	4030006880	S.CER C1608 JB 1H 472K-T	[#46]	
	4030006880	S.CER C1608 JB 1H 472K-T	[#47]	
	4030006880	S.CER C1608 JB 1H 472K-T	[#50]	
C71	4030006880	S.CER C1608 JB 1H 472K-T	[#41] T	141.0/184.3
	4030006880	S.CER C1608 JB 1H 472K-T	[#42]	
	4030006880	S.CER C1608 JB 1H 472K-T	[#46]	
	4030006880	S.CER C1608 JB 1H 472K-T	[#47]	
	4030006880	S.CER C1608 JB 1H 472K-T	[#50]	
C72	4030006880	S.CER C1608 JB 1H 472K-T	[#41] T	138.6/181.2
	4030006880	S.CER C1608 JB 1H 472K-T	[#42]	
	4030006880	S.CER C1608 JB 1H 472K-T	[#46]	
	4030006880	S.CER C1608 JB 1H 472K-T	[#47]	
	4030006880	S.CER C1608 JB 1H 472K-T	[#50]	
C73	4030006880	S.CER C1608 JB 1H 472K-T	T	26.9/178.5
C74	4030006880	S.CER C1608 JB 1H 472K-T	T	23.1/123.3
C75	4340000630	S.MYL ECHU 1H 224JX9	[#41] T	43.2/173.1
	4340000630	S.MYL ECHU 1H 224JX9	[#42]	
	4340000630	S.MYL ECHU 1H 224JX9	[#46]	
	4340000630	S.MYL ECHU 1H 224JX9	[#47]	
	4340000630	S.MYL ECHU 1H 224JX9	[#50]	
C76	4030006880	S.CER C1608 JB 1H 472K-T	T	36.5/140.7
C77	4030006880	S.CER C1608 JB 1H 472K-T	T	36.5/142.0
C78	4030006850	S.CER C1608 JB 1H 471K-T	T	24.4/161.0
C79	4030006850	S.CER C1608 JB 1H 471K-T	T	24.4/165.2
C81	4030006880	S.CER C1608 JB 1H 472K-T	T	27.9/157.8
C82	4510008540	S.ELE EEE1CA100SR	T	23.8/155.4
C84	4340000630	S.MYL ECHU 1H 224JX9	T	39.3/133.4
C85	4340000630	S.MYL ECHU 1H 224JX9	T	35.7/179.6
C86	4030006860	S.CER C1608 JB 1H 102K-T	T	48.6/125.0
C87	4030008560	S.CER C1608 CH 1H 300J-T	T	29.9/146.5
C88	4030008560	S.CER C1608 CH 1H 300J-T	T	29.9/143.4
C89	4030006880	S.CER C1608 JB 1H 472K-T	T	80.2/178.6
C91	4030006880	S.CER C1608 JB 1H 472K-T	T	67.6/150.9
C94	4030006880	S.CER C1608 JB 1H 472K-T	T	67.6/131.7
C98	4030006880	S.CER C1608 JB 1H 472K-T	T	110.8/40.0
C100	4030006880	S.CER C1608 JB 1H 472K-T	T	125.5/36.7
C102	4030006880	S.CER C1608 JB 1H 472K-T	T	140.5/41.6
C104	4030006880	S.CER C1608 JB 1H 472K-T	T	155.0/42.4
C106	4030006880	S.CER C1608 JB 1H 472K-T	T	167.6/45.1
C108	4030006880	S.CER C1608 JB 1H 472K-T	T	185.1/33.2
C110	4030006880	S.CER C1608 JB 1H 472K-T	T	199.3/35.5
C112	4030006880	S.CER C1608 JB 1H 472K-T	T	229.7/56.7
C114	4030006880	S.CER C1608 JB 1H 472K-T	T	251.5/53.5
C116	4030006880	S.CER C1608 JB 1H 472K-T	T	271.8/33.9
C118	4030006880	S.CER C1608 JB 1H 472K-T	T	275.6/33.9
C120	4030006880	S.CER C1608 JB 1H 472K-T	T	110.9/90.2
C122	4030006880	S.CER C1608 JB 1H 472K-T	T	129.0/90.3
C124	4030006880	S.CER C1608 JB 1H 472K-T	T	141.6/90.4
C126	4030006880	S.CER C1608 JB 1H 472K-T	T	154.8/90.3
C128	4030006880	S.CER C1608 JB 1H 472K-T	T	167.4/90.4
C130	4030006880	S.CER C1608 JB 1H 472K-T	T	179.7/90.3
C132	4030006880	S.CER C1608 JB 1H 472K-T	T	192.0/90.7
C134	4030006880	S.CER C1608 JB 1H 472K-T	T	204.3/90.3
C136	4030006880	S.CER C1608 JB 1H 472K-T	T	216.8/90.5
C147	4030006880	S.CER C1608 JB 1H 472K-T	T	193.4/134.5
C148	4030006880	S.CER C1608 JB 1H 472K-T	T	65.9/159.5
C150	4030006880	S.CER C1608 JB 1H 472K-T	T	250.0/58.3
C152	4030006880	S.CER C1608 JB 1H 472K-T	T	193.4/154.1







[TUNER-1 UNIT]

REF NO.	PARTS NO.	DESCRIPTION	M.	H/V LOCATION
C282	4030006880	S.CER C1608 JB 1H 472K-T	T	31.3/164.5
C283	4030006880	S.CER C1608 JB 1H 472K-T	T	31.3/170.7
C284	4030006880	S.CER C1608 JB 1H 472K-T	T	67.6/170.0
C285	4030011330	S.CER C1608 CH 1H 391J-T	T	210.1/192.4
	4030011330	S.CER C1608 CH 1H 391J-T	[#43]	
	4030011330	S.CER C1608 CH 1H 391J-T	[#44]	
	4030011330	S.CER C1608 CH 1H 391J-T	[#48]	
	4030011330	S.CER C1608 CH 1H 391J-T	[#49]	
C286	4030006880	S.CER C1608 JB 1H 472K-T	T	208.6/192.4
	4030006880	S.CER C1608 JB 1H 472K-T	[#44]	
	4030006880	S.CER C1608 JB 1H 472K-T	[#48]	
	4030006880	S.CER C1608 JB 1H 472K-T	[#49]	
C287	4030011190	S.CER GRM31M2C2H270JV01L (GRM42-6) Only	T	71.8/82.0
RL1	6330001071	REL AJQ1341FB01		
RL2	6330001071	REL AJQ1341FB01		
RL3	6330001060	REL APQ 3311 (APQ3311K1)		
RL4	6330000571	REL AR322173FC01		
RL5	6330001060	REL APQ 3311 (APQ3311K1)		
RL6	6330001060	REL APQ 3311 (APQ3311K1)		
RL7	6330001060	REL APQ 3311 (APQ3311K1)		
RL8	6330001060	REL APQ 3311 (APQ3311K1)		
RL9	6330001060	REL APQ 3311 (APQ3311K1)		
RL10	6330001060	REL APQ 3311 (APQ3311K1)		
RL11	6330001060	REL APQ 3311 (APQ3311K1)		
RL12	6330001060	REL APQ 3311 (APQ3311K1)		
RL13	6330001060	REL APQ 3311 (APQ3311K1)		
RL14	6330001060	REL APQ 3311 (APQ3311K1)		
RL15	6330001060	REL APQ 3311 (APQ3311K1)		
RL16	6330001060	REL APQ 3311 (APQ3311K1)		
RL17	6330001060	REL APQ 3311 (APQ3311K1)		
RL18	6330001060	REL APQ 3311 (APQ3311K1)		
RL19	6330001060	REL APQ 3311 (APQ3311K1)		
RL20	6330001060	REL APQ 3311 (APQ3311K1)		
RL21	6330001060	REL APQ 3311 (APQ3311K1)		
RL22	6330001060	REL APQ 3311 (APQ3311K1)		
RL23	6330001060	REL APQ 3311 (APQ3311K1)		
RL24	6330001060	REL APQ 3311 (APQ3311K1)		
RL25	6330000571	REL AR322173FC01		
RL26	6330000571	REL AR322173FC01		
RL27	6330000571	REL AR322173FC01		
CP4	6910009670	S.CHE HK3-S-T	T	33.4/190.0
CP15	6910009670	S.CHE HK3-S-T	T	103.8/4.8
CP38	6910009670	S.CHE HK3-S-T	T	130.0/148.3
CP67	6910009670	S.CHE HK3-S-T	T	11.4/118.4
CP68	6910009670	S.CHE HK3-S-T	T	11.4/124.7
J1	6510028410	CON MR-DS-01-1 <GA>	[#41]	
	6510028410	CON MR-DS-01-1 <GA>	[#42]	
	6510028410	CON MR-DS-01-1 <GA>	[#47]	
J4	6910003141	CON IMSA-9202B-1-02Z041-PT1		
J6	6910003141	CON IMSA-9202B-1-02Z041-PT1		
J9	6510015150	CON ML-800S1V-6P	[#41]	
	6510015150	CON ML-800S1V-6P	[#42]	
	6510015150	CON ML-800S1V-6P	[#47]	
J13	6910003141	CON IMSA-9202B-1-02Z041-PT1		
J16	6510003101	CON RT01T-1.3B(LF)	[#41]	
	6510003101	CON RT01T-1.3B(LF)	[#42]	
	6510003101	CON RT01T-1.3B(LF)	[#47]	
J21	6510003101	CON RT01T-1.3B(LF)	[#41]	
	6510003101	CON RT01T-1.3B(LF)	[#42]	
	6510003101	CON RT01T-1.3B(LF)	[#47]	
P4	6910003120	CON IMSA-9206H-T		
P6	6910003120	CON IMSA-9206H-T		
DS1	5040003250	S.LED RY-SP190SR34-5M <VKH>	T	167.6/134.7
DS2	5040003250	S.LED RY-SP190SR34-5M <VKH>	T	165.9/131.5
DS3	5040003250	S.LED RY-SP190SR34-5M <VKH>	T	164.3/134.7
DS4	5040003250	S.LED RY-SP190SR34-5M <VKH>	T	162.4/131.5
DS5	5040003250	S.LED RY-SP190SR34-5M <VKH>	T	160.7/134.7
DS6	5040003250	S.LED RY-SP190SR34-5M <VKH>	T	158.9/131.5
DS7	5040003250	S.LED RY-SP190SR34-5M <VKH>	T	157.0/134.7
DS8	5040003250	S.LED RY-SP190SR34-5M <VKH>	T	155.4/131.5
DS9	5040003250	S.LED RY-SP190SR34-5M <VKH>	T	153.7/134.7
DS10	5040003250	S.LED RY-SP190SR34-5M <VKH>	T	151.9/131.5
DS11	5040003250	S.LED RY-SP190SR34-5M <VKH>	T	150.2/134.7
DS12	5040003250	S.LED RY-SP190SR34-5M <VKH>	T	148.4/131.6
DS13	5040003250	S.LED RY-SP190SR34-5M <VKH>	T	165.9/143.0
DS14	5040003250	S.LED RY-SP190SR34-5M <VKH>	T	164.3/146.9
DS15	5040003250	S.LED RY-SP190SR34-5M <VKH>	T	148.3/143.0
DS16	5040003250	S.LED RY-SP190SR34-5M <VKH>	T	150.2/147.0
DS17	5040003250	S.LED RY-SP190SR34-5M <VKH>	T	151.9/143.0
DS18	5040003250	S.LED RY-SP190SR34-5M <VKH>	T	153.7/147.0
DS19	5040003250	S.LED RY-SP190SR34-5M <VKH>	T	155.3/143.0
DS20	5040003250	S.LED RY-SP190SR34-5M <VKH>	T	157.2/147.0
DS21	5040003250	S.LED RY-SP190SR34-5M <VKH>	T	158.9/143.0
DS22	5040003250	S.LED RY-SP190SR34-5M <VKH>	T	160.7/147.0
DS23	5040003250	S.LED RY-SP190SR34-5M <VKH>	T	162.5/143.0
DS24	5040003250	S.LED RY-SP190SR34-5M <VKH>	T	127.0/185.1
S1	2260000200	SWI MS621C	[#41]	
	2260000200	SWI MS621C	[#42]	
	2260000200	SWI MS621C	[#46]	
	2260000200	SWI MS621C	[#47]	
	2260000200	SWI MS621C	[#50]	
S2	2260001890	S.SWI SKQDPA	T	154.0/172.9

Eqv.= This component is equivalent to the REF No. component listed above, and may be substituted on parts orders and repairs.

[TUNER-1 UNIT]

REF NO.	PARTS NO.	DESCRIPTION	M.	H/V LOCATION
S3	2260002881	S.SWI HDS408C-E	[#41]	T 137.0/164.2
	2260002881	S.SWI HDS408C-E	[#42]	
	2260002881	S.SWI HDS408C-E	[#46]	
	2260002881	S.SWI HDS408C-E	[#47]	
	2260002881	S.SWI HDS408C-E	[#50]	
S4	2260002881	S.SWI HDS408C-E	[#41]	T 137.0/138.9
	2260002881	S.SWI HDS408C-E	[#42]	
	2260002881	S.SWI HDS408C-E	[#46]	
	2260002881	S.SWI HDS408C-E	[#47]	
	2260002881	S.SWI HDS408C-E	[#50]	
S5	2260002881	S.SWI HDS408C-E	[#41]	T 137.0/121.2
	2260002881	S.SWI HDS408C-E	[#42]	
	2260002881	S.SWI HDS408C-E	[#46]	
	2260002881	S.SWI HDS408C-E	[#47]	
	2260002881	S.SWI HDS408C-E	[#50]	
W18	9011570360	WIR 35/00/110/W06/W06		
W19	9045201001	WIR 74/98/040/X98/X98	[#46]	
	9045201001	WIR 74/98/040/X98/X98	[#50]	
W20	9011570470	WIR 74/98/038/X98/X98	[#41]	
	9011570470	WIR 74/98/038/X98/X98	[#47]	
W21	9011570400	WIR 13/01/065/W04/W04	Only	[#42]
W61	9011570480	WIR 99/09/150/W06/W06 AWM3239 30K	Only	[#42]

M.=Mounted side (T: Mounted on the Top side, B: Mounted on the Bottom side) S.=Surface mount

[MANUAL-1 UNIT]

REF NO.	PARTS NO.	DESCRIPTION	M.	H/V LOCATION
D302	1750000271	S.DIO 1SS301(TE85LF)	T	51.0/71.3
D303	1750000271	S.DIO 1SS301(TE85LF)	T	51.0/82.7
D304	1750000271	S.DIO 1SS301(TE85LF)	T	51.0/96.2
D305	1750002150	S.DIO DB2J31400L	T	65.2/110.0
L302	6110002870	COI LA-473		
L303	6110002870	COI LA-473		
L304	6110002870	COI LA-473		
L305	6110002870	COI LA-473		
L306	6110002870	COI LA-473		
L307	6110002870	COI LA-473		
L308	6110002870	COI LA-473		
L309	6110002870	COI LA-473		
L310	6110002870	COI LA-473		
L311	6110002870	COI LA-473		
L312	6110002870	COI LA-473		
L313	6110002870	COI LA-473		
L314	6110002870	COI LA-473		
L315	6110002870	COI LA-473		
L316	6110002870	COI LA-473		
L317	6110002880	COI LA-474		
L319	6140001550	COI LR-174		
L320	6200003950	S.COI HF50ACC 322513-T	T	42.5/110.0
L321	6200003950	S.COI HF50ACC 322513-T	T	46.0/110.0
R301	7030010870	S.RES ERJ12YJ560U (56)	T	30.1/87.1
R302	7030010870	S.RES ERJ12YJ560U (56)	T	49.9/74.9
R303	7030010870	S.RES ERJ12YJ560U (56)	T	49.9/79.1
R304	7030010620	S.RES ERJ12YJ180U (18)	T	49.9/92.6
R305	7030003620	S.RES ERJ3GEYJ 333 V (33K)	T	61.5/110.0
R306	7030010520	S.RES ERJ1TYJ 101U (100)	T	111.7/108.7
R307	7030010520	S.RES ERJ1TYJ 101U (100)	T	115.4/108.7
R308	7030010520	S.RES ERJ1TYJ 101U (100)	T	119.1/108.7
C301	4030006880	S.CER C1608 JB 1H 472K-T	T	29.0/90.1
C302	4030006880	S.CER C1608 JB 1H 472K-T	T	51.0/68.9
C303	4030006880	S.CER C1608 JB 1H 472K-T	T	50.9/85.1
C304	4030006880	S.CER C1608 JB 1H 472K-T	T	51.0/98.6
C305	4030006880	S.CER C1608 JB 1H 472K-T	T	48.7/109.2
C306	4030011330	S.CER C1608 CH 1H 391J-T	T	61.5/111.6
C309	4320000280	DIP DM20C 122J5		
C310	4320000220	DIP DM19C 681J5		
C311	4320000270	DIP DM20C 102J5		
C312	4010008680	CER DEA1X3F820JA3B		
C313	4010008680	CER DEA1X3F820JA3B		
C314	4010008680	CER DEA1X3F820JA3B		
C315	4010008690	CER DEA1X3F101JA3B		
C316	4010008690	CER DEA1X3F101JA3B		
C317	4010008690	CER DEA1X3F101JA3B		
C318	4010008700	CER DEA1X3F181JA3B		
C319	4010008690	CER DEA1X3F101JA3B		
C320	4010008710	CER DEA1X3D331JA3B		
C321	4010005081	CER DEA1X3F470JC3B-Z		
RL301	6330000840	REL G2R-1 DC12V		
RL302	6330000840	REL G2R-1 DC12V		
RL303	6330000840	REL G2R-1 DC12V		
RL304	6330000571	REL AR322173FC01		
J301	6510003391	CON B03B-EH-S(LF)(SN)		
J302	6910003161	CON IMSA-9202B-2-08Z041-PT1		
J303	6510003101	CON RT01T-1.3B(LF)		
J305	6510003101	CON RT01T-1.3B(LF)		
J307	6510006600	CON RT01N-2.3A		
J308	6510006600	CON RT01N-2.3A		
J309	6510006600	CON RT01N-2.3A		
J310	6510006600	CON RT01N-2.3A		
J311	6510006600	CON RT01N-2.3A		
J312	6510006600	CON RT01N-2.3A		
J313	6510006600	CON RT01N-2.3A		
J314	6510006600	CON RT01N-2.3A		
J315	6510006600	CON RT01N-2.3A		
J316	6510006600	CON RT01N-2.3A		
J317	6510006600	CON RT01N-2.3A		
J318	6510006600	CON RT01N-2.3A		
J319	6510006600	CON RT01N-2.3A		
J320	6510006600	CON RT01N-2.3A		
J321	6510006600	CON RT01N-2.3A		
J322	6510006600	CON RT01N-2.3A		
J323	6510006600	CON RT01N-2.3A		
J324	6910003161	CON IMSA-9202B-2-08Z041-PT1		
J325	6910003161	CON IMSA-9202B-2-08Z041-PT1		
P301	6910003120	CON IMSA-9206H-T		
P302	6910003120	CON IMSA-9206H-T		
P303	6910003120	CON IMSA-9206H-T		
P304	6910003120	CON IMSA-9206H-T		
P306	6910003120	CON IMSA-9206H-T		
P307	6910003120	CON IMSA-9206H-T		
P308	6910003120	CON IMSA-9206H-T		
P309	6910003120	CON IMSA-9206H-T		
P310	6910003120	CON IMSA-9206H-T		
P311	6910003120	CON IMSA-9206H-T		
P312	6910003120	CON IMSA-9206H-T		
P313	6910003120	CON IMSA-9206H-T		
W301	9011570410	WIR 13/02/065/W05/W05		
W302	9011570420	WIR 13/00/060/W05/W05		

Eqv.= This component is equivalent to the REF No. component listed above, and may be substituted on parts orders and repairs.

[MANUAL-1 UNIT]

REF NO.	PARTS NO.	DESCRIPTION	M.	H/V LOCATION
W304	9054500720	WIR 76/98/040/X98/X98		

M.=Mounted side (T: Mounted on the Top side, B: Mounted on the Bottom side) S.=Surface mount

# BOARD LAYOUTS

The combination of top side and bottom side of this page shows the actual configuration of P.C. board.

## • TUNER-1 UNIT (TOP VIEW)

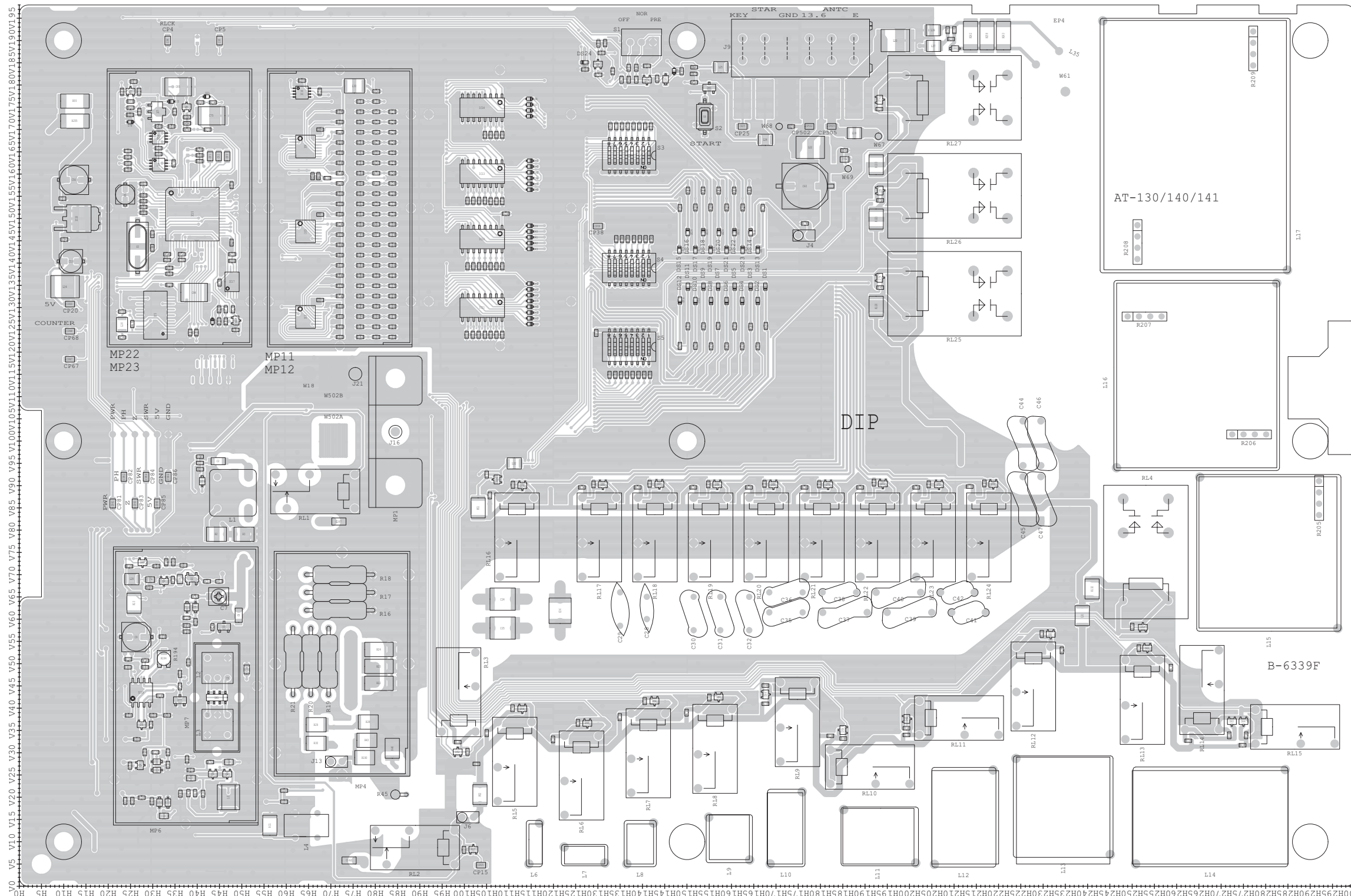

• TUNER-1 UNIT  
(BOTTOM VIEW)

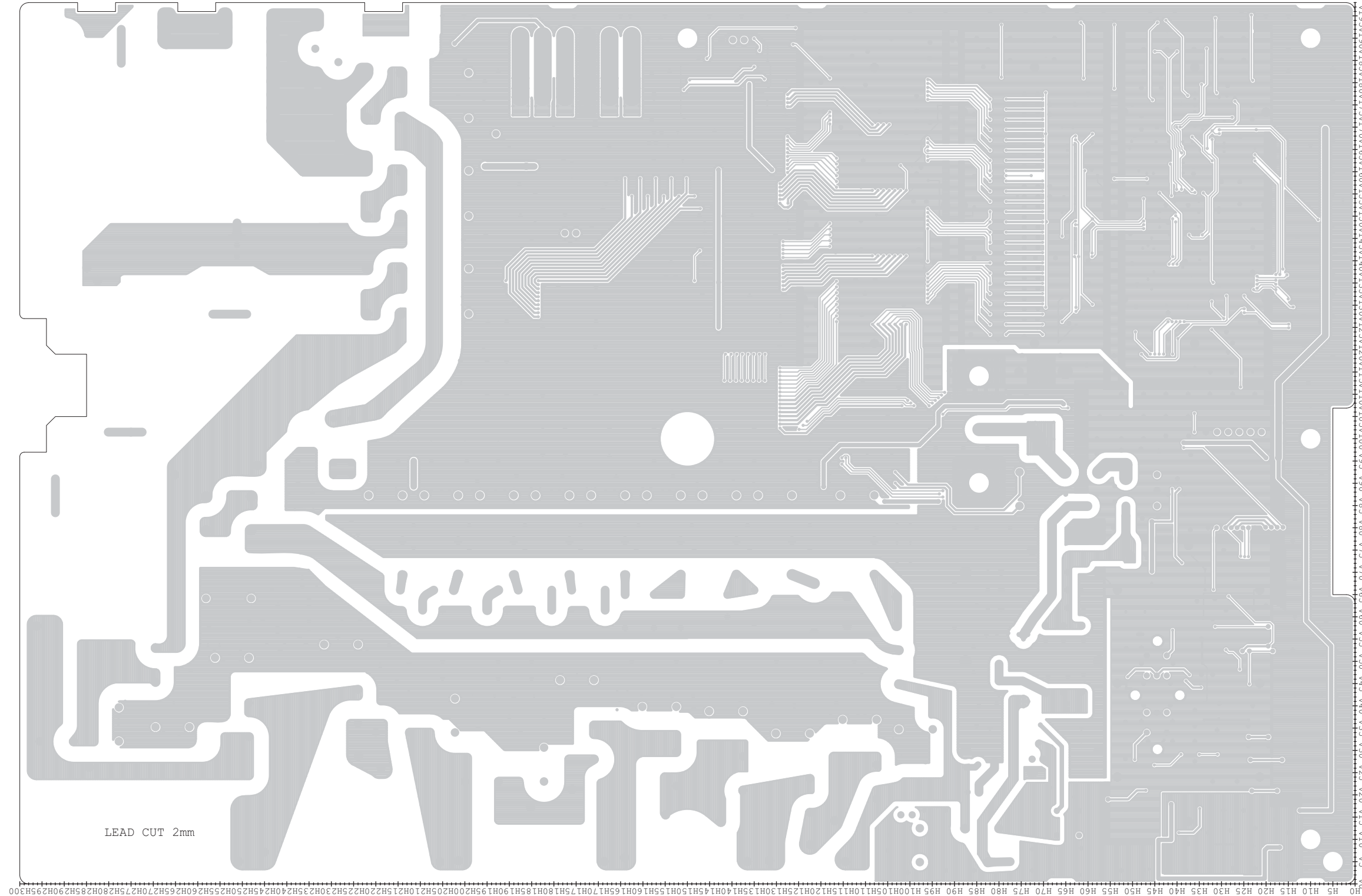



# VOLTAGE DIAGRAM

## • TUNER-1 UNIT

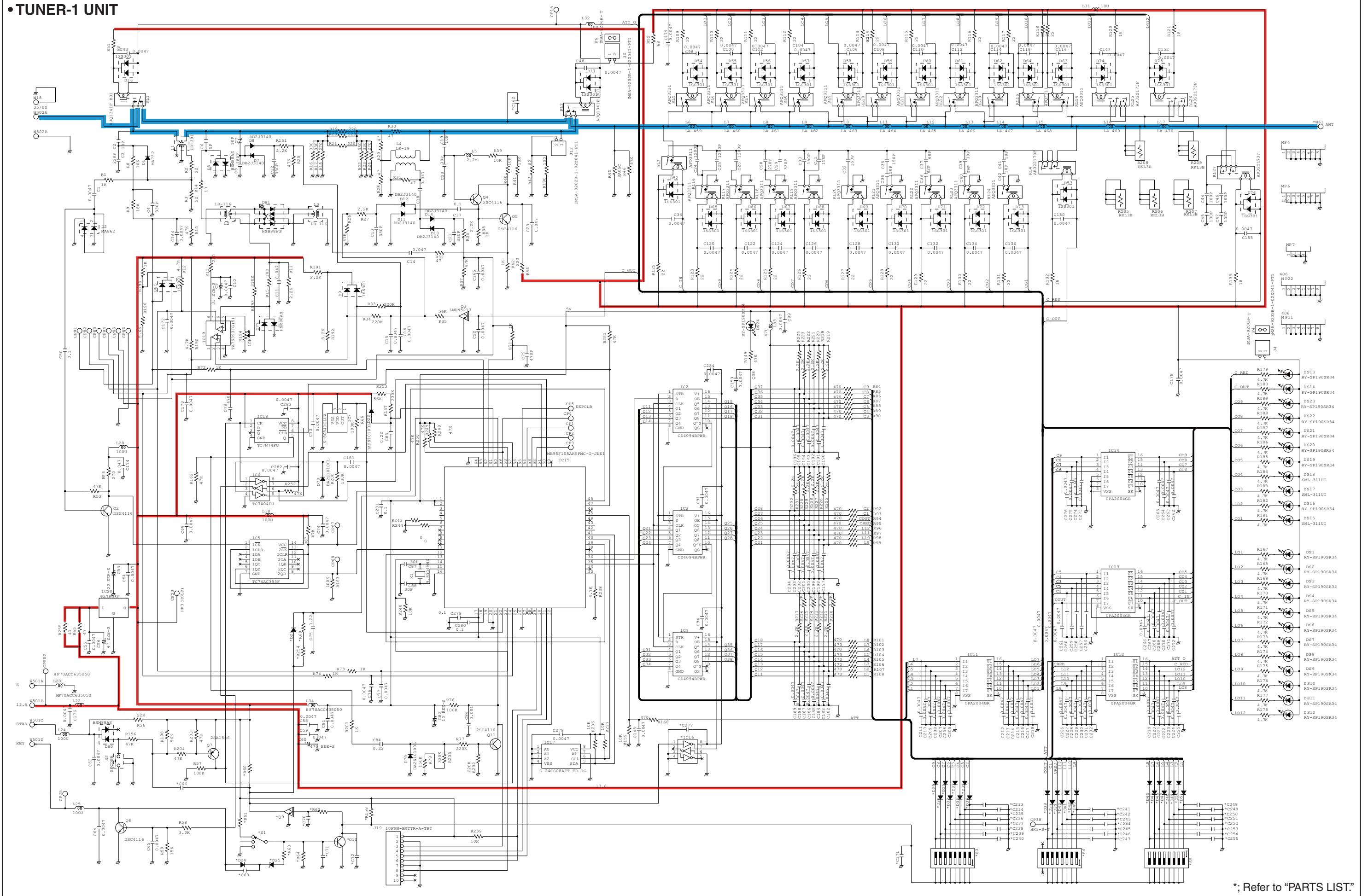

\*; Refer to "PARTS LIST."



# SERVICE MANUAL

HF AUTOMATIC ANTENNA TUNER

**AT-130**  
**AT-130E**  
**AT-140**

---

---

---

---

---

---

## INTRODUCTION

---

This service manual describes the latest service information for the **AT-130/AT-130E/AT-140** HF AUTOMATIC ANTENNA TUNER at the time of publication.

MODEL	SYMBOL	VERSION
AT-130	USA	U.S.A.
	USA-1	U.S.A.-1
	USA-2	U.S.A.-2
AT-130E	EUR	Europe
	EUR-1	Europe-1
AT-140	USA-3	U.S.A.-3

To upgrade quality, any electrical or mechanical parts and internal circuits are subject to change without notice or obligation.



---

## DANGER

---

**NEVER** connect the antenna tuner to an AC outlet or to a DC power supply that uses more than 16 V. This will ruin the antenna tuner.

**DO NOT** expose the antenna tuner to rain, snow or any liquids.

**DO NOT** reverse the polarities of the power supply when connecting the antenna tuner.

---

## ORDERING PARTS

---

Be sure to include the following four points when ordering replacement parts:

1. 10-digit order numbers
2. Component part number and name
3. Equipment model name and unit name
4. Quantity required

### <SAMPLE ORDER>

1140003000 IC    μPD78212CW    AT-130    TUNER UNIT 5 pieces  
8810000660 Screw PH M4×12 SUS    AT-130    Top case    10 pieces  
Addresses are provided on the inside back cover for your convenience.

---

## REPAIR NOTES

---

1. Make sure a problem is internal before disassembling the antenna tuner.
2. **DO NOT** open the antenna tuner until the antenna tuner is disconnected from its power source.
3. **DO NOT** force any of the variable components. Turn them slowly and smoothly.
4. **DO NOT** short any circuits or electronic parts. An insulated tuning tool **MUST** be used for all adjustments.
5. **DO NOT** keep power ON for a long time when the antenna tuner is defective.
6. **READ** the instructions of test equipment thoroughly before connecting equipment to the antenna tuner.

---

## TABLE OF CONTENTS

---

<b>SECTION 1</b>	<b>SPECIFICATIONS</b>	
<b>SECTION 2</b>	<b>INSIDE VIEW</b>	
<b>SECTION 3</b>	<b>CIRCUIT DESCRIPTION</b>	
<b>SECTION 4</b>	<b>ADJUSTMENT PROCEDURES</b>	
<b>SECTION 5</b>	<b>PARTS LIST</b>	
<b>SECTION 6</b>	<b>MECHANICAL PARTS</b>	
<b>SECTION 7</b>	<b>SEMI-CONDUCTOR INFORMATION</b>	
<b>SECTION 8</b>	<b>BOARD LAYOUTS</b>	
8 - 1	TUNER UNIT .....	8 - 1
8 - 2	MANUAL UNIT (AT-130E ONLY) .....	8 - 2
<b>SECTION 9</b>	<b>BLOCK DIAGRAM</b>	
<b>SECTION 10</b>	<b>VOLTAGE DIAGRAM</b>	



# SECTION 1 SPECIFICATIONS

## ■ GENERAL

- Number of memory channels : 45
- Frequency range : 1.6 MHz to 30 MHz with a 7 m (23 ft) or longer antenna element
- Maximum input power : 150 W PEP  
100 W continuous
- Input impedance : 50  $\Omega$
- Minimum operating input power : 5 to 15 W
- Automatic tuning time :  
(General) : Approx. 2 to 3 sec. (max. 15 sec.)  
(Returning to a memorized frequency) : Approx. 1 sec.
- Tuning accuracy (VSWR) : Less than 2.0 : 1  
(after tuning; except for multiples of  $\frac{1}{2} \lambda$ )
- Antenna required : Marconi-type with suitable RF ground  
(More than 7 m (23 ft) is suggested)
- Power supply required : DC 13.6 V  $\pm$  15 % (supplied from HF transceiver)
- Current drain : Less than 2 A
- Usable temperature range :  $-30^{\circ}\text{C}$  to  $+60^{\circ}\text{C}$ ;  $-22^{\circ}\text{F}$  to  $+140^{\circ}\text{F}$
- Dimensions (projections not included) : 230(W)  $\times$  80(H)  $\times$  340(D) mm  
9 $\frac{3}{32}$ (W)  $\times$  3 $\frac{3}{32}$ (H)  $\times$  13 $\frac{13}{32}$ (D) in
- Case construction : Weatherproof
- Weight :  
(AT-130/AT-140) : Approx. 2.5 kg; 5 lb 8 oz  
(AT-130E) : Approx. 2.7 kg; 6 lb
- Control cable : OPC-420 (For [IC-77/78])  
OPC-566 (For [IC-M700PRO], [IC-M710/RT])  
OPC-1147 (For [IC-M802])  
OPC-1186 (For [IC-F7000])

**All stated specifications are subject to change without notice or obligation.**

## SECTION 2 INSIDE VIEW

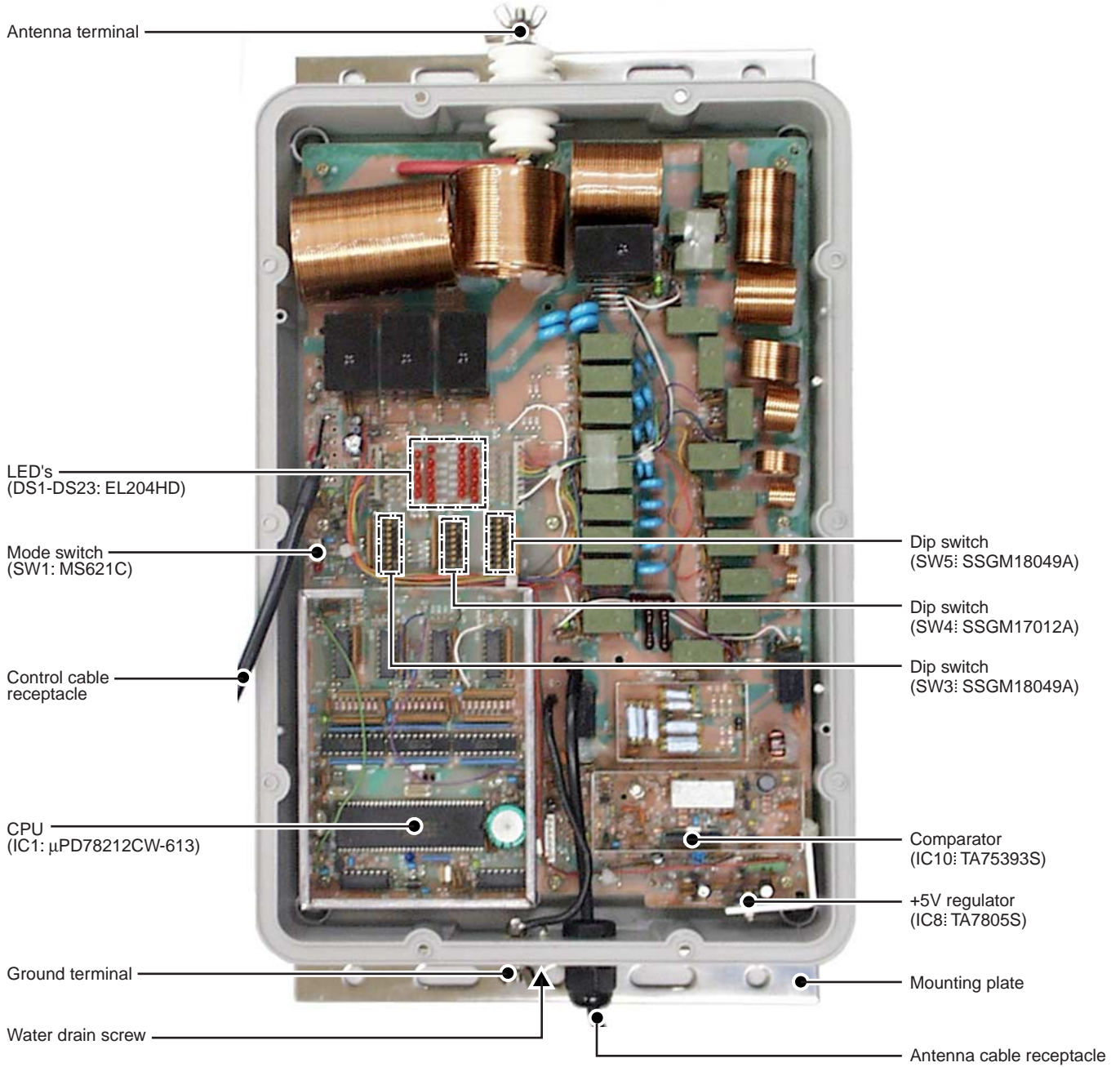

Photo: AT-140

# SECTION 3 CIRCUIT DESCRIPTION

## 3-1 GENERAL

An 8-bit microprocessor controls the AT-130/AT-130E/AT-140. The tuner matches the antenna system to the transceiver by using four kinds of detector circuits. These circuits are:

- (1) FORWARD POWER DETECTOR
- (2) SWR DETECTOR
- (3) PHASE DETECTOR
- (4) IMPEDANCE DETECTOR

Detailed descriptions of each circuit as follows.

### • GENERAL

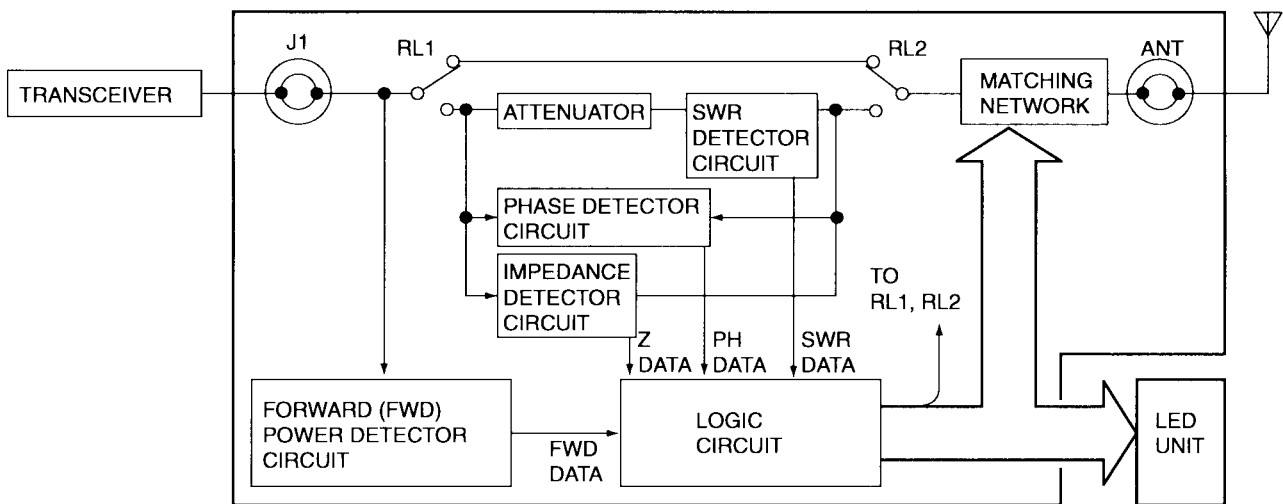

## 3-2 FORWARD (FWD) POWER DETECTOR CIRCUIT

This circuit ensures the input power from the transceiver is low enough to be handled by the attenuator within the tuner.

In the TUNER UNIT, L1 and D1 detects the RF input current. C2 and C3 divide the detected voltage and feed it to IC10a.

## 3-3 SWR DETECTOR CIRCUIT

The reflected power from the antenna system provides a detection voltage.

The voltage doubler, consisting of D13 and D14, rectifies this voltage and passes through the voltage divider formed by R36 and R37.

These SWR data from voltage divider feed into IC1, The CPU. The CPU controls the setting of the coils and capacitors in the matching network.

### • FORWARD POWER DETECTOR CIRCUIT

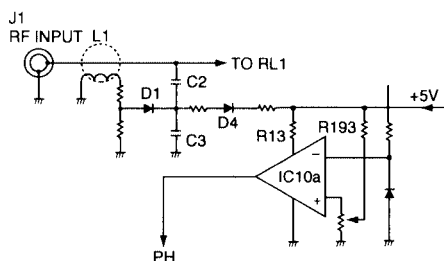

### • SWR DETECTOR CIRCUIT

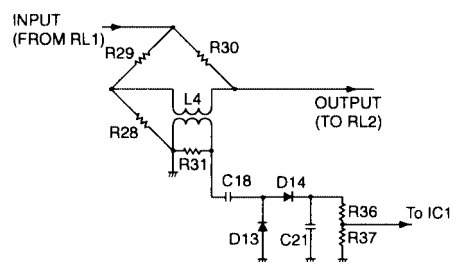

### 3-4 PHASE DETECTOR CIRCUIT

This circuit consists of L2, L3 and IC9. The phase detector's purpose is to detect reactance components and provide a pure resistance.

The output of IC9 is a reference voltage of approximately 4 V when the load of L3 is a pure resistance with no reactance. An inductive load produces an output voltage from IC9 which is lower than the reference voltage, whereas, a capacitive load produces an output voltage higher than the reference voltage. IC10a amplifies the output voltage and passes it to comparator IC10a.

#### • PHASE DETECTOR CIRCUIT

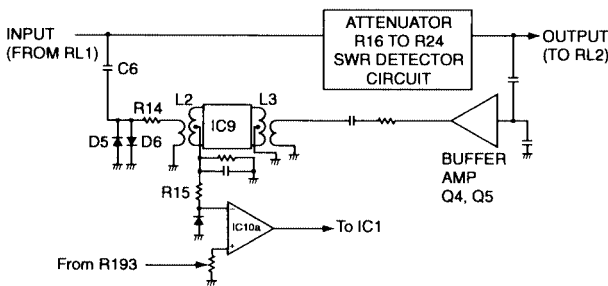

### 3-5 IMPEDANCE DETECTOR CIRCUIT

The tuner uses an attenuator to reduce the transmit power to a very low level. The low power minimizes the risk of interference to other stations while matching an antenna to the transmitter.

The VSWR at the input terminal is usually close to 1:1 even with a large change of impedance at the attenuator output due to the 16 dB of isolation between the input and the matching network.

The circuit uses the constant voltage at D7 and D8 on The TUNER unit as a reference. If the impedance of the attenuator output is higher than 50 Ω, the detected voltage by D11 and D12 is HIGH. If the impedance is lower than 50 Ω, the voltage is LOW. Both the reference and detected voltages feed to comparator IC10b.

#### • IMPEDANCE DETECTOR CIRCUIT

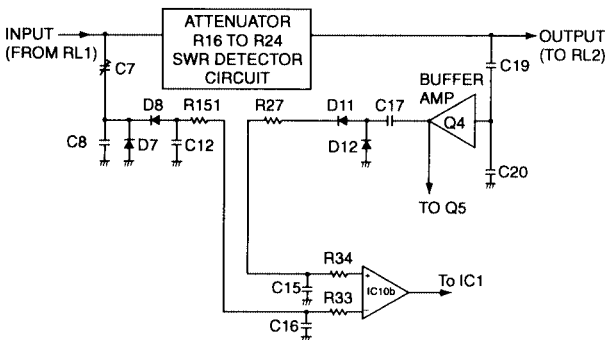

### 3-6 LOGIC CIRCUIT

IC1, The CPU, controls the antenna matching network. The CPU receives +5V through IC8 when DC power is applied to the tuner. This voltage initializes the CPU. The stored program in the Read Only Memory (ROM) IC12 sets each relay to the initial condition.

The tuning program begins only if the START line is at LOW level. RL1 and RL2 activate when RF power at the input antenna connector from the transceiver is present at an appropriate level (See Section 6-2).

The data from the previously described detectors (input RF power, reflected RF power, phase difference, impedance difference) feed into the CPU. The coil data then passes to IC4, the capacitor data to IC3 and the control data to IC2 according to the tuning program.

### 3-8 ANTENNA CURRENT DETECTOR CIRCUIT (MANUAL UNIT — Europe version only)

On the MANUAL UNIT, L319 detects the antenna current. D305 rectifies the detected voltage and feed it to J301 through low-pass filter comprising R305, C305 and C306.

#### • ANTENNA CURRENT DETECTOR CIRCUIT

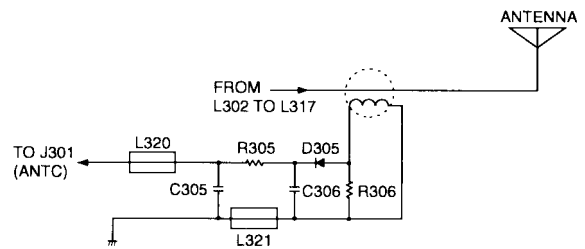



# SECTION 4 ADJUSTMENT PROCEDURES

## 4-1 PREPARATION

### ■ REQUIRED TEST EQUIPMENT

EQUIPMENT	GRADE AND RANGE
DC power supply	Output voltage : Depended on connecting transceiver (Ex; 13.8 V DC) Current capacity : Depended on connecting transceiver (Ex; 30 A or more)
Oscilloscope	Frequency range : DC-20 MHz Measuring range : 0.01-10 V
Transceiver	: Icom transceiver

### • CONNECTION

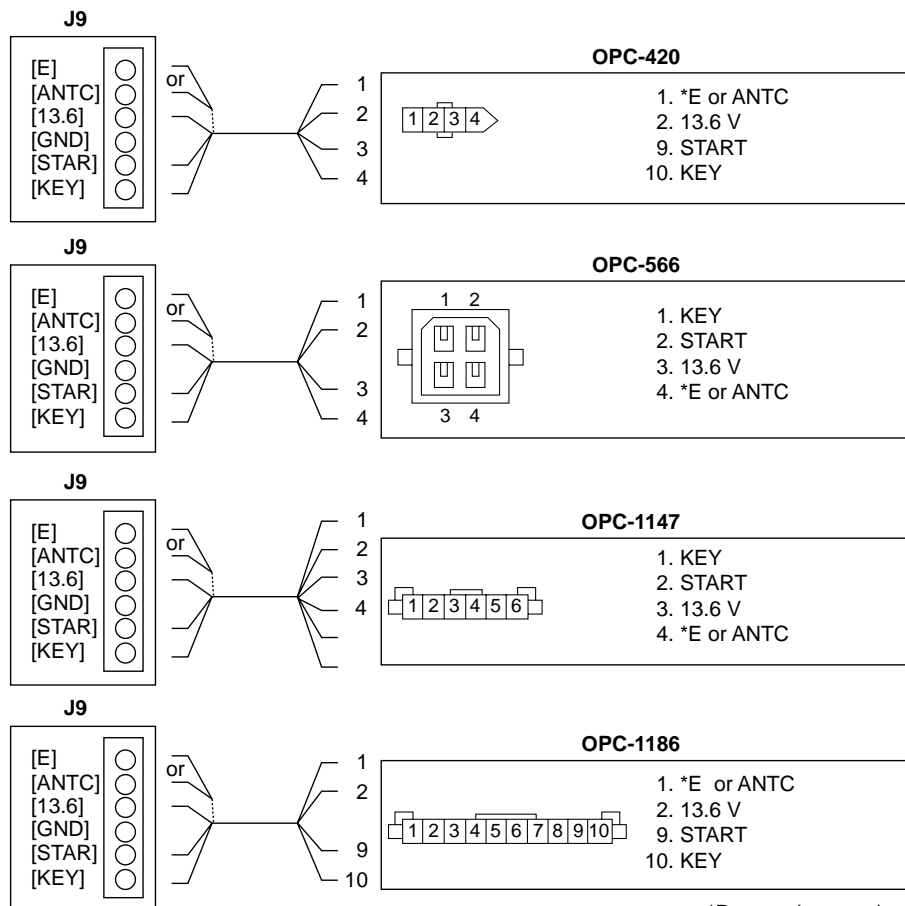
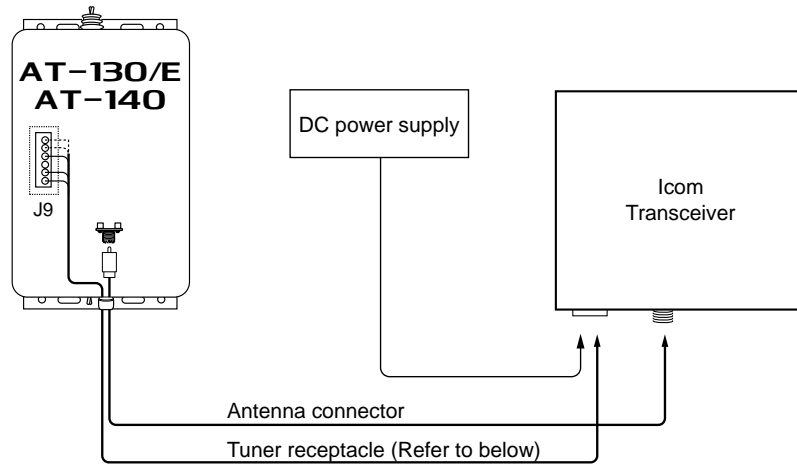

\*Depended on versions

## 4-2 ANTENNA TUNER ADJUSTMENTS

ADJUSTMENT	ADJUSTMENT CONDITION	MEASUREMENT		VALUE	ADJUSTMENT POINT	
		UNIT	LOCATION		UNIT	ADJUST
PHASE DETECTOR CIRCUIT	1 <ul style="list-style-type: none"> <li>• S1 : PRESET</li> <li>• S4-7 : OFF</li> <li>• Short pins of J13.</li> <li>• Disconnect P6 from J6.</li> <li>• Ground J15 with a jumper wire.</li> <li>• TRANSCEIVER               <ul style="list-style-type: none"> <li>Display freq. : 1.6 MHz</li> <li>Output power : 10 W (carrier only)</li> <li>Transmitting</li> </ul> </li> </ul>	TUNER	Connect an oscilloscope to the check point pin 2 of J8.	5 V (Tune R194 just before dropped.)	TUNER	R56
IMPEDANCE DETECTOR CIRCUIT	2 <ul style="list-style-type: none"> <li>• Same as above</li> </ul>		Connect an oscilloscope to check point pin 3 of J8.	5 V (Tune C7 just before drope.)		C7
FORWARD DETECTOR CIRCUIT	3 <ul style="list-style-type: none"> <li>• Same as above</li> </ul>		Connect an oscilloscope to check point pin 1 of J8.	1.4 – 2.4 V		Verify
SWR DETECTOR CIRCUIT	4 <ul style="list-style-type: none"> <li>• Same as above</li> </ul>		Connect an oscilloscope to check point pin 4 of J8.	0 – 0.1 V		Verify

NOTE:
 

- After adjustment, remove the jumper wires from J15 and ground.
- After adjustment, Disconnect pins of J13.
- After adjustment, reconnect P6 to J6 and set S1 to [NORMAL] position.

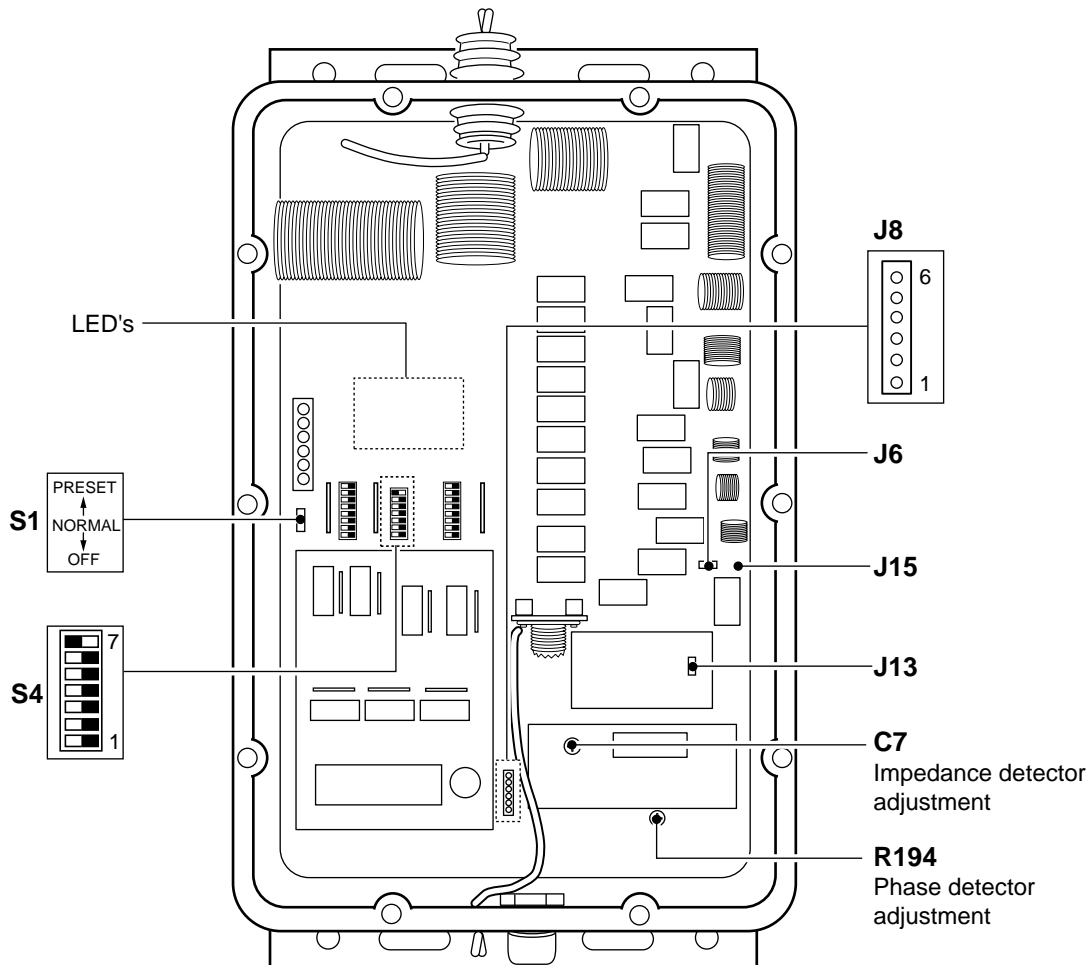

# SECTION 5 PARTS LIST

## [TUNER UNIT]

REF NO.	ORDER NO.	DESCRIPTION	M.
IC1	1140003000	IC μPD78212CW-613	T
IC2	1130006930	IC TC74HC574AP	T
IC3	1130006930	IC TC74HC574AP	T
IC4	1130006930	IC TC74HC574AP	T
IC5	1130005200	IC TC74HC393AP	T
IC6	1130000050	IC TC4013BP	T
IC7	1110005750	IC S-80841CLY-B	T
IC8	1110002020	IC TA7805S	T
IC10	1110000060	IC TA75393S	T
IC11	1160000100	IC μPA2004C	T
IC12	1160000100	IC μPA2004C	T
IC13	1160000100	IC μPA2004C	T
IC14	1160000100	IC μPA2004C	T
Q1	1560000110	FET 2SK241-GR	T
Q2	1530000150	TRANSISTOR 2SC2668-O	T
Q3	1590000350	TRANSISTOR RN1204	T
Q4	1530000110	TRANSISTOR 2SC2458-GR	T
Q5	1530000110	TRANSISTOR 2SC2458-GR	T
Q7	1510000080	TRANSISTOR 2SA1048-GR	T
Q8	1530000110	TRANSISTOR 2SC2458-GR	T
Q9	1590000350	TRANSISTOR RN1204	T
Q10	1530000110	TRANSISTOR 2SC2458-GR	T
Q11	1530000110	TRANSISTOR 2SC2458-GR	T
D1	1710000021	DIODE 1N60 <AMI>	T
D2	1710000580	DIODE 1SS265	T
D3	1710000580	DIODE 1SS265	T
D4	1710000160	DIODE 1SS133	T
D5	1710000021	DIODE 1N60 <AMI>	T
D6	1710000021	DIODE 1N60 <AMI>	T
D7	1710000021	DIODE 1N60 <AMI>	T
D8	1710000021	DIODE 1N60 <AMI>	T
D9	1710000160	DIODE 1SS133	T
D10	1710000160	DIODE 1SS133	T
D11	1710000021	DIODE 1N60 <AMI>	T
D12	1710000021	DIODE 1N60 <AMI>	T
D13	1710000021	DIODE 1N60 <AMI>	T
D14	1710000021	DIODE 1N60 <AMI>	T
D15	1710000160	DIODE 1SS133	T
D16	1710000060	DIODE 1SS55-T4	T
D17	1710000060	DIODE 1SS55-T4	T
D18	1710000350	DIODE 1N4002	T
D19	1710000350	DIODE 1N4002	T
D20	1710000350	DIODE 1N4002	T
D21	1710000160	DIODE 1SS133	T
D22	1710000160	DIODE 1SS133	T
D24	1710000040	DIODE 1S953	T
D25	1730000170	ZENER RD8.2E B1	T
D26	1710000040	DIODE 1S953	T
D29	1710000160	DIODE 1SS133	T
D30	1710000160	DIODE 1SS133	T
D31	1710000160	DIODE 1SS133	T
D32	1710000160	DIODE 1SS133	T
D33	1710000160	DIODE 1SS133	T
D34	1710000160	DIODE 1SS133	T
D35	1710000160	DIODE 1SS133	T
D36	1710000160	DIODE 1SS133	T
D37	1710000160	DIODE 1SS133	T
D38	1710000160	DIODE 1SS133	T
D39	1710000160	DIODE 1SS133	T
D40	1710000160	DIODE 1SS133	T
D41	1710000160	DIODE 1SS133	T
D42	1710000160	DIODE 1SS133	T
D43	1710000160	DIODE 1SS133	T
D44	1710000160	DIODE 1SS133	T
D45	1710000160	DIODE 1SS133	T
D46	1710000160	DIODE 1SS133	T
D47	1710000160	DIODE 1SS133	T
D48	1710000160	DIODE 1SS133	T
D49	1710000160	DIODE 1SS133	T
D50	1710000160	DIODE 1SS133	T
D51	1710000160	DIODE 1SS133	T
D52	1710000060	DIODE 1SS55-T4	T
D53	1710000060	DIODE 1SS55-T4	T
D54	1710000060	DIODE 1SS55-T4	T
D55	1710000060	DIODE 1SS55-T4	T
D56	1710000060	DIODE 1SS55-T4	T

## [TUNER UNIT]

REF NO.	ORDER NO.	DESCRIPTION	M.
D57	1710000060	DIODE 1SS55-T4	T
D58	1710000060	DIODE 1SS55-T4	T
D59	1710000060	DIODE 1SS55-T4	T
D60	1710000060	DIODE 1SS55-T4	T
D61	1710000060	DIODE 1SS55-T4	T
D62	1710000060	DIODE 1SS55-T4	T
D63	1710000060	DIODE 1SS55-T4	T
D64	1710000060	DIODE 1SS55-T4	T
D65	1710000060	DIODE 1SS55-T4	T
D66	1710000060	DIODE 1SS55-T4	T
D67	1710000060	DIODE 1SS55-T4	T
D68	1710000060	DIODE 1SS55-T4	T
D69	1710000060	DIODE 1SS55-T4	T
D70	1710000060	DIODE 1SS55-T4	T
D71	1710000060	DIODE 1SS55-T4	T
D72	1710000060	DIODE 1SS55-T4	T
D73	1710000060	DIODE 1SS55-T4	T
D74	1710000060	DIODE 1SS55-T4	T
D75	1710000060	DIODE 1SS55-T4	T
D76	1710000060	DIODE 1SS55-T4	T
D77	1790001780	DIODE MA700	T
D78	1710000160	DIODE 1SS133	T
D79	1710000160	DIODE 1SS133	T
D80	1790001780	DIODE MA700	T
D81	1790001780	DIODE MA700	T
D82	1790001780	DIODE MA700	T
D83	1790001780	DIODE MA700	T
D84	1790001780	DIODE MA700	T
X1	6050006930	XTAL RF-4A3 FAT NKD (9.8304 MHz)	T
L1	6140000100	COIL LR-22A	T
L2	6140000930	COIL LR-116	T
L3	6140000930	COIL LR-116	T
L4	6140000070	COIL LR-19	T
L5	6180003300	COIL T6-222J (2.2M)	T
L6	6110002750	COIL LA-459	T
L7	6110002760	COIL LA-460	T
L8	6110002770	COIL LA-461	T
L9	6110002780	COIL LA-462	T
L10	6110002790	COIL LA-463	T
L11	6110002800	COIL LA-464	T
L12	6110002810	COIL LA-465	T
L13	6110002820	COIL LA-466	T
L14	6110002830	COIL LA-467	T
L15	6110002840	COIL LA-468	T
L16	6110002850	COIL LA-469	T
L17	6110002860	COIL LA-470	T
L18	6180000900	COIL LAL 03NA 101K	T
L19	6910000670	COIL BL01RN1A1D2B (BL01RN1-A62) [AT-130E] only	T
L20	6910000670	COIL BL01RN1A1D2B (BL01RN1-A62)	T
L22	6910000670	COIL BL01RN1A1D2B (BL01RN1-A62)	T
L23	6910000670	COIL BL01RN1A1D2B (BL01RN1-A62)	T
L24	6180000900	COIL LAL 03NA 101K	T
L25	6180000900	COIL LAL 03NA 101K	T
L26	6910000670	COIL BL01RN1A1D2B (BL01RN1-A62)	T
L27	6910000670	COIL BL01RN1A1D2B (BL01RN1-A62)	T
L28	6180000900	COIL LAL 03NA 101K	T
L29	6180000900	COIL LAL 03NA 101K	T
L30	6910000670	COIL BL01RN1A1D2B (BL01RN1-A62)	T
L31	6180001220	COIL LAL 04NA 100K	T
L32	6180000880	COIL LAL 03NA 100K	T
L33	6180002270	COIL LAL 03NA 470K	T
R1	7010004190	RESISTOR R20J 1 kΩ	T
R2	7010004670	RESISTOR R50XJ 22 Ω	T
R3	7010004670	RESISTOR R50XJ 22 Ω	T
R4	7010003340	RESISTOR ELR20J 330 Ω	T
R5	7010003740	RESISTOR ELR20J 470 kΩ	T
R6	7010003240	RESISTOR ELR20J 47 Ω	T
R8	7010004320	RESISTOR R20J 10 kΩ	T
R9	7010004230	RESISTOR R20J 2.2 kΩ	T
R10	7010004410	RESISTOR R20J 47 kΩ	T
R11	7010003440	RESISTOR ELR20J 2.2 kΩ	T
R12	7010003480	RESISTOR ELR20J 4.7 kΩ	T
R13	7010000290	RESISTOR ELR25J 220 Ω	T

M.=Mounted side (T: Mounted on the Top side, B: Mounted on the Bottom side)

S.=Surface mount

[TUNER UNIT]

REF NO.	ORDER NO.	DESCRIPTION	M.
R14	7010003950	RESISTOR R20J 10 Ω	T
R15	7010004320	RESISTOR R20J 10 kΩ	T
R16	7070000730	RESISTOR CRH200 R-02J 330 Ω	T
R17	7070000731	RESISTOR ERG2SJ 331 (330 Ω)	T
R18	7070000721	RESISTOR ERG2SJ 271 (270 Ω)	T
R19	7070000291	RESISTOR ERG2SJ 221 (220 Ω)	T
R20	7070000291	RESISTOR ERG2SJ 221 (220 Ω)	T
R21	7070000291	RESISTOR ERG2SJ 221 (220 Ω)	T
R22	7070000301	RESISTOR ERG1SJ 331 (330 Ω)	T
R23	7070000301	RESISTOR ERG1SJ 331 (330 Ω)	T
R24	7070000711	RESISTOR ERG1SJ 271 (270 Ω)	T
R25	7010004410	RESISTOR R20J 47 kΩ	T
R26	7010004410	RESISTOR R20J 47 kΩ	T
R27	7010003440	RESISTOR ELR20J 2.2 kΩ	T
R28	7010004690	RESISTOR R50XJ 47 Ω	T
R29	7010004690	RESISTOR R50XJ 47 Ω	T
R30	7010004690	RESISTOR R50XJ 47 Ω	T
R31	7010004690	RESISTOR R50XJ 47 Ω	T
R32	7010004030	RESISTOR R20J 47 Ω	T
R33	7010004490	RESISTOR R20J 220 kΩ	T
R34	7010004490	RESISTOR R20J 220 kΩ	T
R35	7010004420	RESISTOR R20J 56 kΩ	T
R36	7010004230	RESISTOR R20J 2.2 kΩ	T
R37	7010004410	RESISTOR R20J 47 kΩ	T
R38	7010004190	RESISTOR R20J 1 kΩ	T
R39	7010004320	RESISTOR R20J 10 kΩ	T
R40	7010004320	RESISTOR R20J 10 kΩ	T
R41	7010004320	RESISTOR R20J 10 kΩ	T
R42	7010003400	RESISTOR ELR20J 1 kΩ	T
R43	7010001020	RESISTOR R25XJ 82 Ω	T
R44	7010004110	RESISTOR R20J 220 Ω	T
R45	7540000010	ABSORBER DSA-301LA	T
R46	7010000590	RESISTOR ELR25J 47 kΩ	T
R47	7010003200	RESISTOR ELR20J 22 Ω	T
R49	7010000160	RESISTOR ELR25J 18 Ω	T
R51	7010004940	RESISTOR ELR25J 68 Ω	T
R52	7010001010	RESISTOR R25XJ 68 Ω	T
R53	7010004400	RESISTOR R20J 39 kΩ	T
R54	7010003380	RESISTOR ELR20J 680 Ω	T
R55	7100000150	RESISTOR SRW2P 22 Ω (220)	T
R56	7010003580	RESISTOR ELR20J 22 kΩ	T
R57	7010004450	RESISTOR R20J 100 kΩ	T
R58	7010004250	RESISTOR R20J 3.3 kΩ	T
R59	7010003550	RESISTOR ELR20J 15 kΩ	T
R60	7010004230	RESISTOR R20J 2.2 kΩ	T
R61	7010003490	RESISTOR ELR20J 5.6 kΩ	T
R62	7010004110	RESISTOR R20J 220 Ω	T
R63	7010003390	RESISTOR ELR20J 820 Ω	T
R64	7010003620	RESISTOR ELR20J 47 kΩ	T
R66	7010003660	RESISTOR ELR20J 100 kΩ	T
R67	7010004410	RESISTOR R20J 47 kΩ	T
R68	7080001191	RESISTOR RN14K2E 390 kΩ	T
R70	7410000082	ARRAY RGLD4X473J	T
R71	7010003400	RESISTOR ELR20J 1 kΩ	T
R72	7010004190	RESISTOR R20J 1 kΩ	T
R73	7010004190	RESISTOR R20J 1 kΩ	T
R74	7010004190	RESISTOR R20J 1 kΩ	T
R75	7010003320	RESISTOR ELR20J 220 Ω	T
R76	7010003660	RESISTOR ELR20J 100 kΩ	T
R77	7010003700	RESISTOR ELR20J 220 kΩ	T
R78	7080000411	RESISTOR RN14K2E 480 kΩ	T
R79	7410000222	ARRAY RGLD8X473J	T
R80	7410000222	ARRAY RGLD8X473J	T
R81	7410000222	ARRAY RGLD8X473J	T
R82	7010003620	RESISTOR ELR20J 47 kΩ	T
R83	7410000202	ARRAY RGLD8X222J	T
R84	7010004150	RESISTOR R20J 470 Ω	T
R85	7010004150	RESISTOR R20J 470 Ω	T
R86	7010004150	RESISTOR R20J 470 Ω	T
R87	7010004150	RESISTOR R20J 470 Ω	T
R88	7010004150	RESISTOR R20J 470 Ω	T
R89	7010004150	RESISTOR R20J 470 Ω	T
R90	7010004150	RESISTOR R20J 470 Ω	T
R91	7410000202	ARRAY RGLD8X222J	T
R92	7010004150	RESISTOR R20J 470 Ω	T
R93	7010004150	RESISTOR R20J 470 Ω	T
R94	7010004150	RESISTOR R20J 470 Ω	T
R95	7010004150	RESISTOR R20J 470 Ω	T
R96	7010004150	RESISTOR R20J 470 Ω	T
R97	7010004150	RESISTOR R20J 470 Ω	T
R98	7010004150	RESISTOR R20J 470 Ω	T
R99	7010004150	RESISTOR R20J 470 Ω	T
R100	7410000202	ARRAY RGLD8X222J	T
R101	7010004150	RESISTOR R20J 470 Ω	T
R102	7010004150	RESISTOR R20J 470 Ω	T
R103	7010004150	RESISTOR R20J 470 Ω	T
R104	7010004150	RESISTOR R20J 470 Ω	T
R105	7010004150	RESISTOR R20J 470 Ω	T

[TUNER UNIT]

REF NO.	ORDER NO.	DESCRIPTION	M.
R106	7010004150	RESISTOR R20J 470 Ω	T
R107	7010004150	RESISTOR R20J 470 Ω	T
R108	7010004150	RESISTOR R20J 470 Ω	T
R109	7010003990	RESISTOR R20J 22 Ω	T
R111	7010003990	RESISTOR R20J 22 Ω	T
R113	7010003990	RESISTOR R20J 22 Ω	T
R115	7010003990	RESISTOR R20J 22 Ω	T
R117	7010003990	RESISTOR R20J 22 Ω	T
R119	7010003990	RESISTOR R20J 22 Ω	T
R121	7010003990	RESISTOR R20J 22 Ω	T
R123	7010003990	RESISTOR R20J 22 Ω	T
R125	7010003990	RESISTOR R20J 22 Ω	T
R127	7010003990	RESISTOR R20J 22 Ω	T
R129	7010003990	RESISTOR R20J 22 Ω	T
R131	7010003990	RESISTOR R20J 22 Ω	T
R133	7010003200	RESISTOR ELR20J 22 Ω	T
R135	7010003990	RESISTOR R20J 22 Ω	T
R137	7010003990	RESISTOR R20J 22 Ω	T
R139	7010003990	RESISTOR R20J 22 Ω	T
R141	7010003990	RESISTOR R20J 22 Ω	T
R143	7010003990	RESISTOR R20J 22 Ω	T
R145	7010003990	RESISTOR R20J 22 Ω	T
R147	7010003990	RESISTOR R20J 22 Ω	T
R149	7010004150	RESISTOR R20J 470 Ω	T
R150	7010003480	RESISTOR ELR20J 4.7 kΩ	T
R151	7010003440	RESISTOR ELR20J 2.2 kΩ	T
R152	7010000940	RESISTOR R25XJ 18 Ω	T
R154	7010000940	RESISTOR R25XJ 18 Ω	T
R156	7010003620	RESISTOR ELR20J 47 kΩ	T
R157	7080001191	RESISTOR RN14K2E 390 kΩ	T
R158	7010003450	RESISTOR ELR20J 2.7 kΩ	T
R159	7010003530	RESISTOR ELR20J 10 kΩ	T
R160	7010003360	RESISTOR ELR20J 470 Ω	T
R161	7010003620	RESISTOR ELR20J 47 kΩ	T
R162	7010003620	RESISTOR ELR20J 47 kΩ	T
R163	7010004450	RESISTOR R20J 100 kΩ	T
R164	7010004450	RESISTOR R20J 100 kΩ	T
R165	7010000940	RESISTOR R25XJ 18 Ω	T
R167	7010003410	RESISTOR ELR20J 1.2 kΩ	T
R168	7010003410	RESISTOR ELR20J 1.2 kΩ	T
R169	7010003410	RESISTOR ELR20J 1.2 kΩ	T
R170	7010003410	RESISTOR ELR20J 1.2 kΩ	T
R171	7010003410	RESISTOR ELR20J 1.2 kΩ	T
R172	7010003410	RESISTOR ELR20J 1.2 kΩ	T
R173	7010003410	RESISTOR ELR20J 1.2 kΩ	T
R174	7010003410	RESISTOR ELR20J 1.2 kΩ	T
R175	7010003410	RESISTOR ELR20J 1.2 kΩ	T
R176	7010003410	RESISTOR ELR20J 1.2 kΩ	T
R177	7010003410	RESISTOR ELR20J 1.2 kΩ	T
R178	7010003410	RESISTOR ELR20J 1.2 kΩ	T
R179	7010003410	RESISTOR ELR20J 1.2 kΩ	T
R180	7010003410	RESISTOR ELR20J 1.2 kΩ	T
R181	7010003410	RESISTOR ELR20J 1.2 kΩ	T
R182	7010003410	RESISTOR ELR20J 1.2 kΩ	T
R183	7010003410	RESISTOR ELR20J 1.2 kΩ	T
R184	7010003410	RESISTOR ELR20J 1.2 kΩ	T
R185	7010003410	RESISTOR ELR20J 1.2 kΩ	T
R186	7010003410	RESISTOR ELR20J 1.2 kΩ	T
R187	7010003410	RESISTOR ELR20J 1.2 kΩ	T
R188	7010003410	RESISTOR ELR20J 1.2 kΩ	T
R189	7010003410	RESISTOR ELR20J 1.2 kΩ	T
R190	7010001030	RESISTOR R25XJ 100 Ω	T
R191	7010001190	RESISTOR R25XJ 2.2 kΩ	T
R192	7010003520	RESISTOR ELR20J 8.2 kΩ	T
R193	7010003720	RESISTOR ELR20J 330 kΩ	T
R194	7310000660	TRIMMER RH0621C14J19A (103)	T
R195	7010003400	RESISTOR ELR20J 1 kΩ	T
R196	7010003490	RESISTOR ELR20J 5.6 kΩ	T
R197	7010005210	RESISTOR R20J 10 MΩ	T
R198	7010004420	RESISTOR R20J 56 kΩ	T
R200	7010003660	RESISTOR ELR20J 100 kΩ	T
R201	7010004190	RESISTOR R20J 1 kΩ	T
R202	7010003700	RESISTOR ELR20J 220 kΩ	T
R203	7010003620	RESISTOR ELR20J 47 kΩ	T
R204	7010004410	RESISTOR R20J 47 kΩ	T
R205	7410000352	ARRAY RGLD3X104J	T
R206	7410000352	ARRAY RGLD3X104J	T
R207	7410000352	ARRAY RGLD3X104J	T
R208	7410000352	ARRAY RGLD3X104J	T
R209	7410000352	ARRAY RGLD3X104J	T
C1	4020000990	CYLINDER UP050 B 473K-NA-CZ	T
C2	4010005610	CERAMIC HM60SJ SL 100D 500V	T
C3	4010000380	CERAMIC DD106-601 SL 221J 50V	T
C4	4010000410	CERAMIC DD107 SL 331J 50V	T
C5	4020000990	CYLINDER UP050 B 473K-NA-CZ	T
C6	4010005660	CERAMIC HM60SJ SL 220J 500V	T

M.=Mounted side (T: Mounted on the Top side, B: Mounted on the Bottom side)

S.=Surface mount

[TUNER UNIT]

REF NO.	ORDER NO.	DESCRIPTION	M.
C7	4610000740	TRIMMER ECV-1ZW 10X53T	T
C8	4010000360	CERAMIC DD106 SL 181J 50V	T
C9	4510005110	ELECTROLYTIC 16 MV 33 HC	T
C10	4010000520	CERAMIC DD107-601 B 472K 50V	T
C11	4020000990	CYLINDER UP050 B 473K-NA-CZ	T
C12	4010000410	CERAMIC DD107 SL 331J 50V	T
C13	4010000410	CERAMIC DD107 SL 331J 50V	T
C14	4020000990	CYLINDER UP050 B 473K-NA-CZ	T
C15	4020001000	CERAMIC RPER11H472K2P1A01B	T
C16	4010000520	CERAMIC DD107-601 B 472K 50V	T
C17	4020000980	CYLINDER UP050 B 104K-NA-CZ	T
C18	4020000990	CYLINDER UP050 B 473K-NA-CZ	T
C19	4020000420	CYLINDER UP050 SL 100J	T
C20	4010000210	CERAMIC DD104 SL 300J 50V	T
C21	4010000410	CERAMIC DD107 SL 331J 50V	T
C22	4010000520	CERAMIC DD107-601 B 472K 50V	T
C23	4020000990	CYLINDER UP050 B 473K-NA-CZ	T
C24	4320000661	DIP MICA KD20C 122J5A	T
C25	4320000661	DIP MICA KD20C 122J5A	T
C26	4320000661	DIP MICA KD20C 122J5A	T
C28	4010004740	CERAMIC DE1207 SL 271J 2KV	T
C29	4010004750	CERAMIC DE1510 SL 331J 2KV	T
C30	4010004280	CERAMIC DE1207 SL 151J 3KV	T
C31	4010004280	CERAMIC DE1207 SL 151J 3KV	T
C32	4010004280	CERAMIC DE1207 SL 151J 3KV	T
C34	4010000520	CERAMIC DD107-601 B 472K 50V	T
C35	4010004280	CERAMIC DE1207 SL 151J 3KV	T
C36	4010004280	CERAMIC DE1207 SL 151J 3KV	T
C37	4010004790	CERAMIC DEC1X3J680JC4B (DE1210SL680J)	T
C38	4010004260	CERAMIC DE0907 SL 820J 3KV	T
C39	4010004770	CERAMIC DEC1X3J390JC4B (DE0910SL390J)	T
C40	4010004770	CERAMIC DEC1X3J390JC4B (DE0910SL390J)	T
C41	4010005040	CERAMIC DE0707 SL 180J 3KV	T
C42	4010005040	CERAMIC DE0707 SL 180J 3KV	T
C43	4010000520	CERAMIC DD107-601 B 472K 50V	T
C44	4010004810	CERAMIC DEC1X3J101JC4B (DE1310SL101J)	T
C45	4010004810	CERAMIC DEC1X3J101JC4B (DE1310SL101J)	T
C46	4010004810	CERAMIC DEC1X3J101JC4B (DE1310SL101J)	T
C47	4010004810	CERAMIC DEC1X3J101JC4B (DE1310SL101J)	T
C48	4010000520	CERAMIC DD107-601 B 472K 50V	T
C50	4020000980	CYLINDER UP050 B 104K-NA-CZ	T
C52	4010000520	CERAMIC DD107-601 B 472K 50V	T
C53	4510003900	ELECTROLYTIC 16 MV 22 HW	T
C54	4010000520	CERAMIC DD107-601 B 472K 50V	T
C55	4010000520	CERAMIC DD107-601 B 472K 50V	T
C56	4510005120	ELECTROLYTIC 16 MV 47 HC	T
C57	4010000520	CERAMIC DD107-601 B 472K 50V	T
C58	4010000520	CERAMIC DD107-601 B 472K 50V	T
C59	4020000990	CYLINDER UP050 B 473K-NA-CZ	T
C60	4510004590	ELECTROLYTIC 16 MV 470 HC	T
C61	4010000520	CERAMIC DD107-601 B 472K 50V	T
C62	4010000520	CERAMIC DD107-601 B 472K 50V	T
C64	4010000520	CERAMIC DD107-601 B 472K 50V	T
C65	4010000520	CERAMIC DD107-601 B 472K 50V	T
C66	4010000520	CERAMIC DD107-601 B 472K 50V	T
C68	4020001000	CERAMIC RPER11H472K2P1A01B	T
C69	4010000500	CERAMIC DD104 B 102K 50V	T
C70	4010000520	CERAMIC DD107-601 B 472K 50V	T
C71	4010000520	CERAMIC DD107-601 B 472K 50V	T
C72	4020001000	CERAMIC RPER11H472K2P1A01B	T
C73	4020001000	CERAMIC RPER11H472K2P1A01B	T
C74	4010000520	CERAMIC DD107-601 B 472K 50V	T
C75	4310000520	MYLAR 50 F2D 224J	T
C76	4010000520	CERAMIC DD107-601 B 472K 50V	T
C77	4010000520	CERAMIC DD107-601 B 472K 50V	T
C78	4010000430	CERAMIC DD108-601 SL 471J 50V	T
C79	4010000460	CERAMIC DD104 B 471K 50V	T
C81	4020001000	CERAMIC RPER11H472K2P1A01B	T
C82	4550000340	TANTALUM DN 1C 100M	T
C83	4510005460	ELECTROLYTIC FYDOH 474Z	T
C84	4310000520	MYLAR 50 F2D 224J	T
C85	4310000520	MYLAR 50 F2D 224J	T
C86	4010000500	CERAMIC DD104 B 102K 50V	T
C87	4010000810	CERAMIC DD104 CH 300J 50V	T
C88	4010000810	CERAMIC DD104 CH 300J 50V	T
C89	4020001000	CERAMIC RPER11H472K2P1A01B	T
C90	4530000250	ARRAY B8XC0112-33N	T
C91	4010000520	CERAMIC DD107-601 B 472K 50V	T
C92	4020001000	CERAMIC RPER11H472K2P1A01B	T
C93	4530000250	ARRAY B8XC0112-33N	T
C94	4010000520	CERAMIC DD107-601 B 472K 50V	T
C95	4010000520	CERAMIC DD107-601 B 472K 50V	T
C96	4530000250	ARRAY B8XC0112-33N	T
C98	4010000520	CERAMIC DD107-601 B 472K 50V	T
C100	4010000520	CERAMIC DD107-601 B 472K 50V	T
C102	4010000520	CERAMIC DD107-601 B 472K 50V	T
C104	4010000520	CERAMIC DD107-601 B 472K 50V	T
C106	4010000520	CERAMIC DD107-601 B 472K 50V	T

[TUNER UNIT]

REF NO.	ORDER NO.	DESCRIPTION	M.
C108	4010000520	CERAMIC DD107-601 B 472K 50V	T
C110	4010000520	CERAMIC DD107-601 B 472K 50V	T
C112	4010000520	CERAMIC DD107-601 B 472K 50V	T
C114	4010000520	CERAMIC DD107-601 B 472K 50V	T
C116	4010000520	CERAMIC DD107-601 B 472K 50V	T
C118	4010000520	CERAMIC DD107-601 B 472K 50V	T
C120	4010000520	CERAMIC DD107-601 B 472K 50V	T
C122	4010000520	CERAMIC DD107-601 B 472K 50V	T
C124	4010000520	CERAMIC DD107-601 B 472K 50V	T
C126	4010000520	CERAMIC DD107-601 B 472K 50V	T
C128	4010000520	CERAMIC DD107-601 B 472K 50V	T
C130	4010000520	CERAMIC DD107-601 B 472K 50V	T
C132	4010000520	CERAMIC DD107-601 B 472K 50V	T
C134	4010000520	CERAMIC DD107-601 B 472K 50V	T
C136	4010000520	CERAMIC DD107-601 B 472K 50V	T
C137	4530000250	ARRAY B8XC0112-33N	T
C138	4530000250	ARRAY B8XC0112-33N	T
C139	4530000250	ARRAY B8XC0112-33N	T
C140	4530000250	ARRAY B8XC0112-33N	T
C141	4530000250	ARRAY B8XC0112-33N	T
C142	4530000250	ARRAY B8XC0112-33N	T
C144	4530000050	ARRAY B5RC0126-33N	T
C147	4010000520	CERAMIC DD107-601 B 472K 50V	T
C148	4020001000	CERAMIC RPER11H472K2P1A01B	T
C150	4010000520	CERAMIC DD107-601 B 472K 50V	T
C152	4010000520	CERAMIC DD107-601 B 472K 50V	T
C153	4010000520	CERAMIC DD107-601 B 472K 50V	T
C155	4010000520	CERAMIC DD107-601 B 472K 50V	T
C156	4020001000	CERAMIC RPER11H472K2P1A01B	T
C162	4010005610	CERAMIC HM60SJ SL 100D 500 V [AT-130E]	T
	4010005660	CERAMIC HM60SJ SL 220J 500V [OTHER]	T
C163	4020001000	CERAMIC RPER11H472K2P1A01B	T
C164	4010000520	CERAMIC DD107-601 B 472K 50V	T
C165	4010000520	CERAMIC DD107-601 B 472K 50V	T
C166	4530000250	ARRAY B8XC0112-33N	T
C167	4530000250	ARRAY B8XC0112-33N	T
C168	4530000250	ARRAY B8XC0112-33N	T
C169	4010000520	CERAMIC DD107-601 B 472K 50V	T
C170	4020001000	CERAMIC RPER11H472K2P1A01B	T
C171	4010000520	CERAMIC DD107-601 B 472K 50V	T
C172	4010000520	CERAMIC DD107-601 B 472K 50V	T
C173	4010000520	CERAMIC DD107-601 B 472K 50V	T
C174	4020000990	CYLINDER UP050 B 473K-NA-CZ	T
C175	4020001000	CERAMIC RPER11H472K2P1A01B	T
C176	4010000520	CERAMIC DD107-601 B 472K 50V	T
C177	4020001000	CERAMIC RPER11H472K2P1A01B	T
C178	4010000520	CERAMIC DD107-601 B 472K 50V	T
C179	4010000520	CERAMIC DD107-601 B 472K 50V	T
C181	4020001000	CERAMIC RPER11H472K2P1A01B	T
C182	4010003930	CERAMIC DD06 SL 270K 500V	T
RL1	6330001070	RELAY AJQ1341 B01	T
RL2	6330001070	RELAY AJQ1341 B01	T
RL3	6330001060	RELAY APQ 3311	T
RL4	6330000570	RELAY AR-39251	T
RL5	6330001060	RELAY APQ 3311	T
RL6	6330001060	RELAY APQ 3311	T
RL7	6330001060	RELAY APQ 3311	T
RL8	6330001060	RELAY APQ 3311	T
RL9	6330001060	RELAY APQ 3311	T
RL10	6330001060	RELAY APQ 3311	T
RL11	6330001060	RELAY APQ 3311	T
RL12	6330001060	RELAY APQ 3311	T
RL13	6330001060	RELAY APQ 3311	T
RL14	6330001060	RELAY APQ 3311	T
RL15	6330001060	RELAY APQ 3311	T
RL16	6330001060	RELAY APQ 3311	T
RL17	6330001060	RELAY APQ 3311	T
RL18	6330001060	RELAY APQ 3311	T
RL19	6330001060	RELAY APQ 3311	T
RL20	6330001060	RELAY APQ 3311	T
RL21	6330001060	RELAY APQ 3311	T
RL22	6330001060	RELAY APQ 3311	T
RL23	6330001060	RELAY APQ 3311	T
RL24	6330001060	RELAY APQ 3311	T
RL25	6330000570	RELAY AR-39251	T
RL26	6330000570	RELAY AR-39251	T
RL27	6330000570	RELAY AR-39251	T
J1	6510000130	CONNECTOR FM MDR MI [AT-130/E] only	T
J4	6910003140	CONNECTOR IMSA-9202B-1-02T	T
J5	6910003140	CONNECTOR IMSA-9202B-1-02T	T
J6	6910003140	CONNECTOR IMSA-9202B-1-02T	T
J8	6510024500	CONNECTOR B06B-XH-A	T
J9	6510015150	CONNECTOR ML-800S1V-6P [AT-130/E] only	T
J13	6910003140	CONNECTOR IMSA-9202B-1-02T	T

M.=Mounted side (T: Mounted on the Top side, B: Mounted on the Bottom side)

S.=Surface mount



[TUNER UNIT]

REF NO.	ORDER NO.	DESCRIPTION		M.
J15	6510003100	CONNECTOR	RT01T-1.3B	T
J16	6510003100	CONNECTOR	RT01T-1.3B [AT-130/E] only	T
P4	6910003120	CONNECTOR	IMSA-9206H-T	T
P5	6910003120	CONNECTOR	IMSA-9206H-T	T
P6	6910003120	CONNECTOR	IMSA-9206H-T	T
DS1	5040002860	LED	EL-204HD	T
DS2	5040002860	LED	EL-204HD	T
DS3	5040002860	LED	EL-204HD	T
DS4	5040002860	LED	EL-204HD	T
DS5	5040002860	LED	EL-204HD	T
DS6	5040002860	LED	EL-204HD	T
DS7	5040002860	LED	EL-204HD	T
DS8	5040002860	LED	EL-204HD	T
DS9	5040002860	LED	EL-204HD	T
DS10	5040002860	LED	EL-204HD	T
DS11	5040002860	LED	EL-204HD	T
DS12	5040002860	LED	EL-204HD	T
DS13	5040002860	LED	EL-204HD	T
DS14	5040002860	LED	EL-204HD	T
DS15	5040002860	LED	EL-204HD	T
DS16	5040002860	LED	EL-204HD	T
DS17	5040002860	LED	EL-204HD	T
DS18	5040002860	LED	EL-204HD	T
DS19	5040002860	LED	EL-204HD	T
DS20	5040002860	LED	EL-204HD	T
DS21	5040002860	LED	EL-204HD	T
DS22	5040002860	LED	EL-204HD	T
DS23	5040002860	LED	EL-204HD	T
DS24	5040002860	LED	EL-204HD	T
S1	2260000200	SWITCH	MS621C	T
S2	2260000580	SWITCH	SKHLAD035A	T
S3	2260000830	SWITCH	SSGM18049A	T
S4	2260000610	SWITCH	SSGM17012A	T
S5	2260000830	SWITCH	SSGM18049A	T
W1	7120000010	JUMPER	JPW 02A	T
W2	6910001030	JUMPER	IPS-1041-4	T
W3	6910001030	JUMPER	IPS-1041-4	T
W4	6910001030	JUMPER	IPS-1041-4	T
W5	6910001020	JUMPER	IPS-1041-2	T
W6	6910001030	JUMPER	IPS-1041-4	T
W7	6910001030	JUMPER	IPS-1041-4	T
W8	6910001020	JUMPER	IPS-1041-2	T
W9	6910001020	JUMPER	IPS-1041-2	T
W10	6910001020	JUMPER	IPS-1041-2	T
W11	6910001020	JUMPER	IPS-1041-2	T
W12	6910001030	JUMPER	IPS-1041-4	T
W13	6910001030	JUMPER	IPS-1041-4	T
W16	6910001020	JUMPER	IPS-1041-2	T
W17	9040401015	WIRE	74/98/045/X98/X98	T
W19	9045201001	WIRE	74/98/040/X98/X98 [AT-130/E] only	T
W20	9045201001	WIRE	74/98/040/X98/X98 [AT-130/140] only	T
W36	6910001030	JUMPER	IPS-1041-4	T
W37	9040401015	WIRE	74/98/045/X98/X98	T
W38	9040401015	WIRE	74/98/045/X98/X98	T
W39	9040401015	WIRE	74/98/045/X98/X98	T
W40	9040401015	WIRE	74/98/045/X98/X98	T
W42	6910001030	JUMPER	IPS-1041-4	T
W49	6910001030	JUMPER	IPS-1041-4	T
W50	6910001030	JUMPER	IPS-1041-4	T
W51	6910001030	JUMPER	IPS-1041-4	T
W52	6910001030	JUMPER	IPS-1041-4	T
W53	6910001030	JUMPER	IPS-1041-4	T
W54	6910001030	JUMPER	IPS-1041-4	T
W55	6910001030	JUMPER	IPS-1041-4	T
W56	6910001030	JUMPER	IPS-1041-4	T
W57	6910001030	JUMPER	IPS-1041-4	T
W58	6910001030	JUMPER	IPS-1041-4	T
W59	6910001030	JUMPER	IPS-1041-4	T
W60	6910001030	JUMPER	IPS-1041-4	T
W70	6910001030	JUMPER	IPS-1041-4	T
W71	6910001030	JUMPER	IPS-1041-4	T
W72	6910001020	JUMPER	IPS-1041-2	T
W73	6910001030	JUMPER	IPS-1041-4	T
W74	6910001030	JUMPER	IPS-1041-4	T
W75	6910001030	JUMPER	IPS-1041-4	T
W76	6910001020	JUMPER	IPS-1041-2	T
W77	7120000010	JUMPER	JPW 02A	T
W78	6910001030	JUMPER	IPS-1041-4	T
W79	6910001020	JUMPER	IPS-1041-2	T

M.=Mounted side (T: Mounted on the Top side, B: Mounted on the Bottom side)

[TUNER UNIT]

REF NO.	ORDER NO.	DESCRIPTION		M.
W80	6910001030	JUMPER	IPS-1041-4	T
W81	6910001030	JUMPER	IPS-1041-4	T
W82	6910001020	JUMPER	IPS-1041-2	T
W83	6910001020	JUMPER	IPS-1041-2	T
W84	6910001020	JUMPER	IPS-1041-2	T
W85	6910001030	JUMPER	IPS-1041-4	T
W87	6910001030	JUMPER	IPS-1041-4	T
W88	6910001030	JUMPER	IPS-1041-4	T
W89	6910001030	JUMPER	IPS-1041-4	T
W90	6910001020	JUMPER	IPS-1041-2	T
W91	6910001030	JUMPER	IPS-1041-4	T
W92	6910001020	JUMPER	IPS-1041-2	T
W93	6910001030	JUMPER	IPS-1041-4	T
W94	6910001030	JUMPER	IPS-1041-4	T
W95	6910001030	JUMPER	IPS-1041-4	T
W96	7120000010	JUMPER	JPW 02A	T
W97	7120000010	JUMPER	JPW 02A	T
W98	6910001030	JUMPER	IPS-1041-4	T
W99	6910001020	JUMPER	IPS-1041-2	T
W100	6910001020	JUMPER	IPS-1041-2	T
W102	6910001030	JUMPER	IPS-1041-4	T
W104	6910001020	JUMPER	IPS-1041-2	T
W105	6910001020	JUMPER	IPS-1041-2	T
W106	6910001020	JUMPER	IPS-1041-2	T
W107	6910001020	JUMPER	IPS-1041-2	T
W108	6910001030	JUMPER	IPS-1041-4	T
W109	6910001020	JUMPER	IPS-1041-2	T
W110	6910001030	JUMPER	IPS-1041-4	T
W111	6910001020	JUMPER	IPS-1041-2	T
W112	6910001030	JUMPER	IPS-1041-4	T
W113	6910001030	JUMPER	IPS-1041-4	T
W114	6910001020	JUMPER	IPS-1041-2	T
W115	6910001030	JUMPER	IPS-1041-4	T
W116	6910001020	JUMPER	IPS-1041-2	T
W117	6910001020	JUMPER	IPS-1041-2	T
W120	6910001030	JUMPER	IPS-1041-4	T
W121	7120000010	JUMPER	JPW 02A	T
W122	6910001030	JUMPER	IPS-1041-4	T
W123	6910001030	JUMPER	IPS-1041-4	T
W124	6910001020	JUMPER	IPS-1041-2	T
W125	6910001030	JUMPER	IPS-1041-4	T
W126	6910001030	JUMPER	IPS-1041-4	T
W127	6910001030	JUMPER	IPS-1041-4	T
W128	6910001030	JUMPER	IPS-1041-4	T
W129	6910001030	JUMPER	IPS-1041-4	T
W130	6910001030	JUMPER	IPS-1041-4	T
W131	6910001020	JUMPER	IPS-1041-2	T
W132	6910001030	JUMPER	IPS-1041-4	T
W133	6910001030	JUMPER	IPS-1041-4	T
W134	6910001030	JUMPER	IPS-1041-4	T
W135	6910001030	JUMPER	IPS-1041-4	T
W136	6910001030	JUMPER	IPS-1041-4	T
W137	6910001020	JUMPER	IPS-1041-2	T
W138	6910001020	JUMPER	IPS-1041-2	T
W139	6910001020	JUMPER	IPS-1041-2	T
W140	6910001020	JUMPER	IPS-1041-2	T
W141	6910001020	JUMPER	IPS-1041-2	T
W142	6910001030	JUMPER	IPS-1041-4	T
W144	6910001020	JUMPER	IPS-1041-2	T
W145	6910001030	JUMPER	IPS-1041-4	T
W146	6910001030	JUMPER	IPS-1041-4	T
W147	6910001020	JUMPER	IPS-1041-2	T
W148	6910001020	JUMPER	IPS-1041-2	T
W149	6910001030	JUMPER	IPS-1041-4	T
W150	6910001030	JUMPER	IPS-1041-4	T
W151	6910001030	JUMPER	IPS-1041-4	T
W152	7120000010	JUMPER	JPW 02A	T
W153	7120000010	JUMPER	JPW 02A [AT-140] only	T
W157	6910001030	JUMPER	IPS-1041-4	T
W158	7120000010	JUMPER	JPW 02A	T
W159	9045201001	WIRE	74/98/040/X98/X98	T
W160	6910001020	JUMPER	IPS-1041-2	T
W161	6910001030	JUMPER	IPS-1041-4	T
W162	6910001020	JUMPER	IPS-1041-2	T
W163	6910001020	JUMPER	IPS-1041-2	T
W164	6910001030	JUMPER	IPS-1041-4	T
W165	6910001020	JUMPER	IPS-1041-2	T
W168	6910001020	JUMPER	IPS-1041-2	T
W169	9040401015	WIRE	74/98/045/X98/X98 [AT-140] only	T
W170	9040401015	WIRE	74/98/045/X98/X98 [AT-140] only	T
W171	6910001020	JUMPER	IPS-1041-2 [AT-140] only	T
W172	6910001020	JUMPER	IPS-1041-2 [AT-140] only	T
W174	6910001020	JUMPER	IPS-1041-2 [AT-140] only	T
W176	6910001020	JUMPER	IPS-1041-2 [AT-140] only	T

S.=Surface mount

**[TUNER UNIT]**

REF NO.	ORDER NO.	DESCRIPTION		M.
WS1	8970020241	OTHER	EX1157 J BOARD SET-1 (10)/TU	T
WS2	8600030510	OTHER	EX1157 J03TU [OTHER]	T
	8970020250	OTHER	EX1157 J LEAD SET (3) /TU [AT-130E]	T
WS3	8600030510	OTHER	EX1157 J03TU [AT-130E]	T
	8600030520	OTHER	EX1157 J02TU [OTHER]	T
WS4	8600030520	OTHER	EX1157 J02TU [AT-130E]	T
	8970020260	OTHER	EX1157 J LEAD SET (2) /TU [OTHER]	T
WS5	8600030530	OTHER	EX1157 P01TU [AT-130E]	T
EP1	0910037487	PCB	B 3678G	
EP2	9030602001	TUBE	IRRAX 1 (d) L=10 mm	T
EP3	9029403902	TUBE	IRRAX 1 (d) L=5 mm	T
EP4	0910037981	PCB	B 3758A [AT-130/E] only	

**[MANUAL UNIT]**

REF NO.	ORDER NO.	DESCRIPTION		M.
RL304	6330000570	RELAY	AR-39251	T
J301	6510002250	CONNECTOR	TL25P03V1	T
J302	6910003160	CONNECTOR	IMSA-9202B-2-08T	T
J303	6510003100	CONNECTOR	RT01T-1.3B	T
J305	6510003100	CONNECTOR	RT01T-1.3B	T
J307	6510006600	CONNECTOR	RT01N-2.3A	T
J308	6510006600	CONNECTOR	RT01N-2.3A	T
J309	6510006600	CONNECTOR	RT01N-2.3A	T
J310	6510006600	CONNECTOR	RT01N-2.3A	T
J311	6510006600	CONNECTOR	RT01N-2.3A	T
J312	6510006600	CONNECTOR	RT01N-2.3A	T
J313	6510006600	CONNECTOR	RT01N-2.3A	T
J314	6510006600	CONNECTOR	RT01N-2.3A	T
J315	6510006600	CONNECTOR	RT01N-2.3A	T
J316	6510006600	CONNECTOR	RT01N-2.3A	T
J317	6510006600	CONNECTOR	RT01N-2.3A	T
J318	6510006600	CONNECTOR	RT01N-2.3A	T
J319	6510006600	CONNECTOR	RT01N-2.3A	T
J320	6510006600	CONNECTOR	RT01N-2.3A	T
J321	6510006600	CONNECTOR	RT01N-2.3A	T
J322	6510006600	CONNECTOR	RT01N-2.3A	T
J323	6510006600	CONNECTOR	RT01N-2.3A	T
P301	6910003120	CONNECTOR	IMSA-9206H-T	T
P302	6910003120	CONNECTOR	IMSA-9206H-T	T
P303	6910003120	CONNECTOR	IMSA-9206H-T	T
P304	6910003120	CONNECTOR	IMSA-9206H-T	T
W304	9054500720	WIRE	76/98/040/X98/X98	T
WS1	8970020270	OTHER	EX1157 J LEAD SET (3) /MN	T
WS2	8600030540	OTHER	EX1157 P305MN	T
EP301	0910015134	PCB	B 1238D	

**[MANUAL UNIT] ([AT-130E] ONLY)**

REF NO.	ORDER NO.	DESCRIPTION		M.
D301	1710000030	DIODE	1S1555	T
D302	1710000030	DIODE	1S1555	T
D303	1710000030	DIODE	1S1555	T
D304	1710000030	DIODE	1S1555	T
D305	1710000021	DIODE	1N60 <AMI>	T
L302	6110002870	COIL	LA-473	T
L303	6110002870	COIL	LA-473	T
L304	6110002870	COIL	LA-473	T
L305	6110002870	COIL	LA-473	T
L306	6110002870	COIL	LA-473	T
L307	6110002870	COIL	LA-473	T
L308	6110002870	COIL	LA-473	T
L309	6110002870	COIL	LA-473	T
L310	6110002870	COIL	LA-473	T
L311	6110002870	COIL	LA-473	T
L312	6110002870	COIL	LA-473	T
L313	6110002870	COIL	LA-473	T
L314	6110002870	COIL	LA-473	T
L315	6110002870	COIL	LA-473	T
L316	6110002870	COIL	LA-473	T
L317	6110002880	COIL	LA-474	T
L319	6140001550	COIL	LR-174	T
L320	6910000670	COIL	BL01RN1A1D2B (BL01RN1-A62)	T
L321	6910000670	COIL	BL01RN1A1D2B (BL01RN1-A62)	T
R301	7010001000	RESISTOR	R25XJ 56 Ω	T
R302	7010001000	RESISTOR	R25XJ 56 Ω	T
R303	7010001000	RESISTOR	R25XJ 56 Ω	T
R304	7010000940	RESISTOR	R25XJ 18 Ω	T
R305	7010001340	RESISTOR	R25XJ 33 kΩ	T
R306	7070000341	RESISTOR	ERG1SJ 330 (33 Ω)	T
C301	4010000520	CERAMIC	DD107-601 B 472K 50V	T
C302	4010000520	CERAMIC	DD107-601 B 472K 50V	T
C303	4010000520	CERAMIC	DD107-601 B 472K 50V	T
C304	4010000520	CERAMIC	DD107-601 B 472K 50V	T
C305	4010000520	CERAMIC	DD107-601 B 472K 50V	T
C306	4010000420	CERAMIC	DD107-601 SL 391J 50V	T
C309	4320000661	DIP MICA	KD20C 122J5A	T
C310	4320000681	DIP MICA	KD19C 681J5A	T
C311	4320000651	DIP MICA	KD20C 102J5A	T
C312	4010004260	CERAMIC	DE0907 SL 820J 3KV	T
C313	4010004260	CERAMIC	DE0907 SL 820J 3KV	T
C314	4010004260	CERAMIC	DE0907 SL 820J 3KV	T
C315	4010004250	CERAMIC	DE1007 SL 101J 3KV	T
C316	4010004250	CERAMIC	DE1007 SL 101J 3KV	T
C317	4010004250	CERAMIC	DE1007 SL 101J 3KV	T
C318	4010004290	CERAMIC	DE1310 SL 181J 3KV	T
C319	4010004290	CERAMIC	DE1310 SL 181J 3KV	T
C320	4010005010	CERAMIC	DE1105 SL 331J 1KV	T
C321	4010005080	CERAMIC	DEA1X3F470JC3B (DE0707SL470J)	T
RL301	6330000840	RELAY	G2R-1 DC12V	T
RL302	6330000840	RELAY	G2R-1 DC12V	T
RL303	6330000840	RELAY	G2R-1 DC12V	T

M.=Mounted side (T: Mounted on the Top side, B: Mounted on the Bottom side)

S.=Surface mount

# SECTION 6 MECHANICAL PARTS

## [CHASSIS PARTS]

REF. NO.	ORDER NO.	DESCRIPTION	QTY.
W501	8900014990	Cable OPC-1468 [AT-140] only	1
W502	8900011400	Cable OPC-1164 [AT-140] only	1
EP501	6910000880	Sheet NC-1 (SUS) [AT-130/E] only	1
EP502	6910000880	Sheet NC-1 (SUS) [AT-130/E] only	1
MP501	8310006540	High voltage wiring seal	1
MP502	8010003411	Case (A)-1 [USA][EUR][USA-2]	1
	8010016911	Case (I)-1 [USA-1][EUR-1]	1
	8010019030	1157 U-case [AT-140]	1
MP503	8010003331	Case (B)-1 [USA][EUR][USA-2]	1
	8010016921	Case (J)-1 [USA-1][EUR-1]	1
	8010019020	1157 L-case [AT-140]	1
MP504	8930006900	Mounting plate	2
MP505	8930006540	Waterproof seal	1
MP506	8930002800	O ring (G)	2
MP507	8930006550	Sealing washer (A) [AT-130/E] only	1
MP508	8930006560	Sealing washer (C)	1
MP509	8930006570	Sealing washer (D)	4
MP510	6910000470	Pair insulator	1
MP512	8310027360	1157 caution seal (P) [AT-130] only	1
	8310053950	Caution seal (P) [AT-140] only	1
MP517	8810000620	Screw PH M3 ×13 SUS [AT-130/E] only	1
MP518	8830000230	Nut M3 SUS [AT-130/E] only	1
MP519	8810003480	Hexagon bolt M5 ×60 SUS	1
MP520	8860000160	Earth lug B8 (M5) AG BS	1
MP521	8850000500	Spring washer M5 SUS	1
MP522	8850000180	Flat washer M5 SUS	1
MP523	8830000250	Nut M5 SUS	1
MP524	8860000190	Earth lug (M5) AG BS	1
MP525	8850000600	Gear Washer M5 SUS	1
MP526	8830000370	Wing nut M5 SUS	1
MP527	8810003470	Hexagon bolt M5 ×20 SUS	1
MP528	8860000160	Earth lug B8 (M5) AG BS	1
MP529	8850000500	Spring washer M5 SUS	1
MP530	8850000180	Flat washer M5 SUS	1
MP531	8830000250	Nut M5 SUS	1
MP532	8860000190	Earth lug D5 (M5) AG BS	1
MP533	8850000600	Gear Washer M5 SUS	1
MP534	8830000370	Wing nut M5 SUS	1
MP535	8810002800	Screw trass head M5 ×10 SUS	4
MP536	8810000660	Screw PH M4 ×14 SUS	10
MP537	8810001480	Screw PH A M5 ×10 SUS	2
MP538	8810001690	Screw PH B0 3 ×8 (PL) [AT-130E]	6
	8810001690	Screw PH B0 3 ×8 (PL) [AT-130/140]	9
MP539	8830000240	Nut M4 SUS	10
MP541	8930006570	Sealing washer (D)	1
MP544	8930006570	Sealing washer (D)	1
MP545	8930006550	Sealing washer (A) [AT-130/E] only	1
MP546	8810000620	Screw PH M3 ×16 SUS [AT-130/E] only	1
MP547	8830000230	Nut M3 SUS [AT-130/E] only	1
MP548	8930010360	Spacer D=4 L=28 T=0.6 [AT-130E] only	3
MP549	8810004260	Screw PH B1 M3 ×40 [AT-130E] only	3
MP550	8850000130	Flat washer M3 NI BS [AT-130E] only	3
MP551	8950001980	Cable tie-140 [AT-140] only	1
MP552	6910014570	Super ground (FGA13-08B) [AT-140] only	1
MP553	6910014570	Super ground (FGA13-08B) [AT-140] only	1

## [TUNER UNIT]

REF. NO.	ORDER NO.	DESCRIPTION	QTY.
MP1	8930006910	Connector angle [AT-130/E] only	1
MP2	8510000821	RF case (B)-1	1
MP3	8510000840	RF case (B) upper cover	1
MP4	8510001081	Shield case (A)-1	1
MP5	8510001101	Shield case (A) cover (A)-1	1
MP6	8510004810	545 shield case	1
MP7	8510002020	MIX shield case	1
MP8	8410000100	DR heatsink	1
MP9	8810003170	Setscrew A M3 ×8 [AT-130/E] only	2
MP10	8810003160	Setscrew A M3 ×6 [AT-130/E] only	2
MP11	8810003180	Setscrew A M3 ×10	1
MP12	8830000190	Nut M3 NI BS	1
MP13	8510003350	RF case (B) lower case (A)	1
MP16	8860000130	Earth lug B5 (M3) AG BS [AT-130/E] only	1
MP17	8860000130	Earth lug B5 (M3) AG BS [AT-130E] only	1
MP18	8930000230	Stat (S) [AT-130E] only	1
MP19	8830000190	Nut M3 NI BS [AT-130E] only	1
MP20	8930017190	Earth spring (F) [USA-1][EUR-1] only	2
MP21	8810003290	Setscrew B M3 ×6 [AT-130E] only	1
MP22	8930004041	TR terminal-1 [AT-140] only	1
MP23	8930004041	TR terminal-1 [AT-140] only	1

## [ACCESSORIES]

REF. NO.	ORDER NO.	DESCRIPTION	QTY.
W701	8900004200	Cable OPC-412	1
MP701	8820000440	U-bolt A SUS	2
MP702	8010000010	U-bolt plate	2
MP703	8830000260	Nut M6 SUS	4
MP704	8850000510	Spring washer M6 SUS	4
MP705	8850000190	Flat washer M6 SUS	4
MP706	8810001500	Screw PH A M6 ×30 SUS	4
MP707	8810003500	Hexagon bolt M6 ×50 SUS	4
MP708	8850000200	Flat washer M6 SUS	8
MP709	8830000260	Nut M6 SUS	4
MP710	8850000510	Spring washer M6 SUS	4
MP711	6950000010	Waterproof cap	1

**Screw abbreviations** A,B0,B1: Self-tapping  
 PH: Pan head BS: Brass  
 NI: Nickel SUS: Stainless

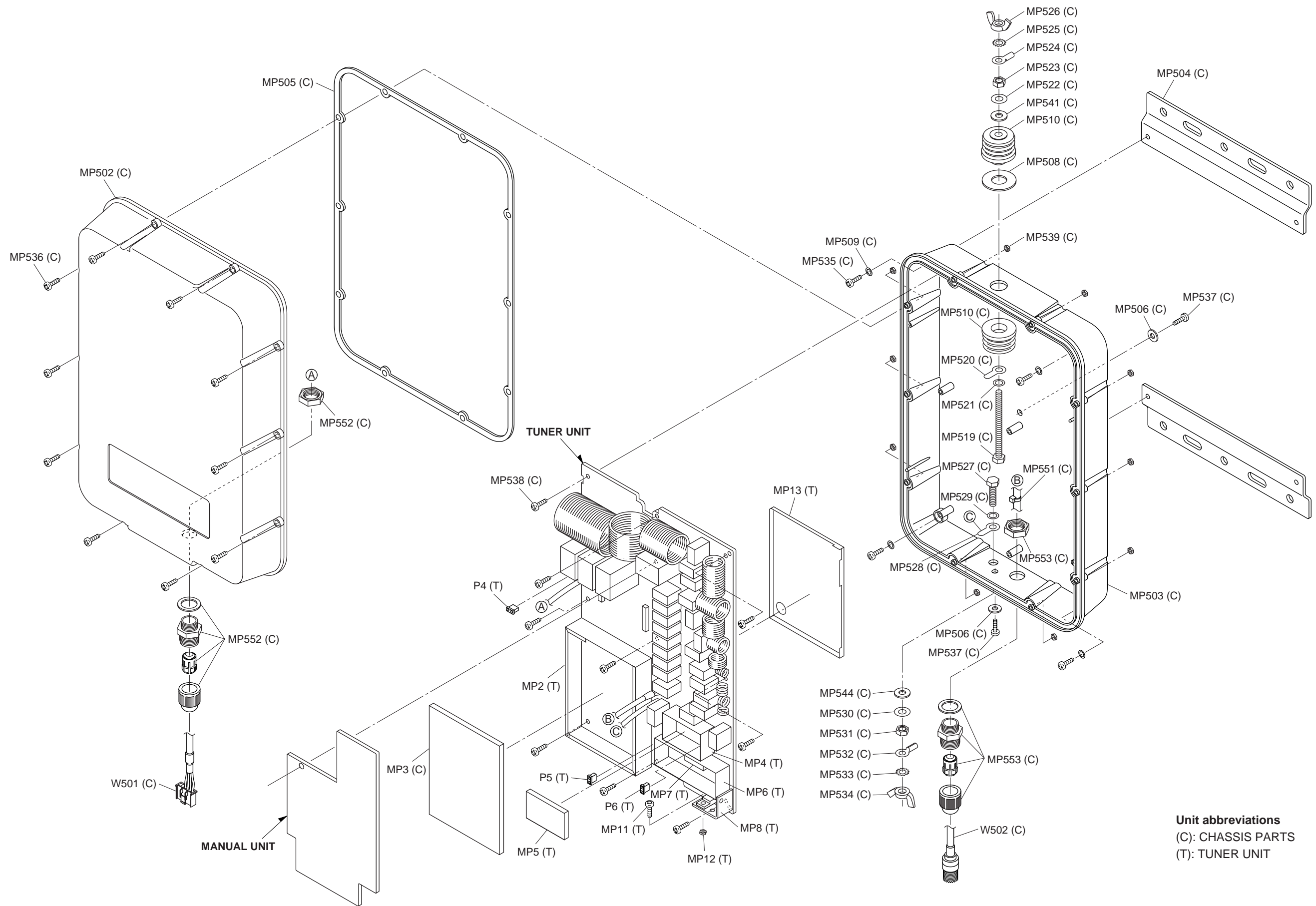

# SECTION 7 SEMI-CONDUCTOR INFORMATION

## • TRANSISTORS AND FET'S

<p>2SA1048 GR</p>	<p>2SC2458 GR</p>	<p>2SC2688 O</p>	<p>2SK241 GR</p>	<p>RN1204</p>
-------------------	-------------------	------------------	------------------	---------------

## • DIODES

<p>1N60</p>	<p>1N4002</p>	<p>1S953</p>	<p>1S1555</p>	<p>1SS55</p>
<p>1SS133</p>	<p>1SS265</p>	<p>MA700</p>	<p>RD8.2E B1</p>	



# SECTION 8 BOARD LAYOUTS

## 8-1 TUNER UNIT

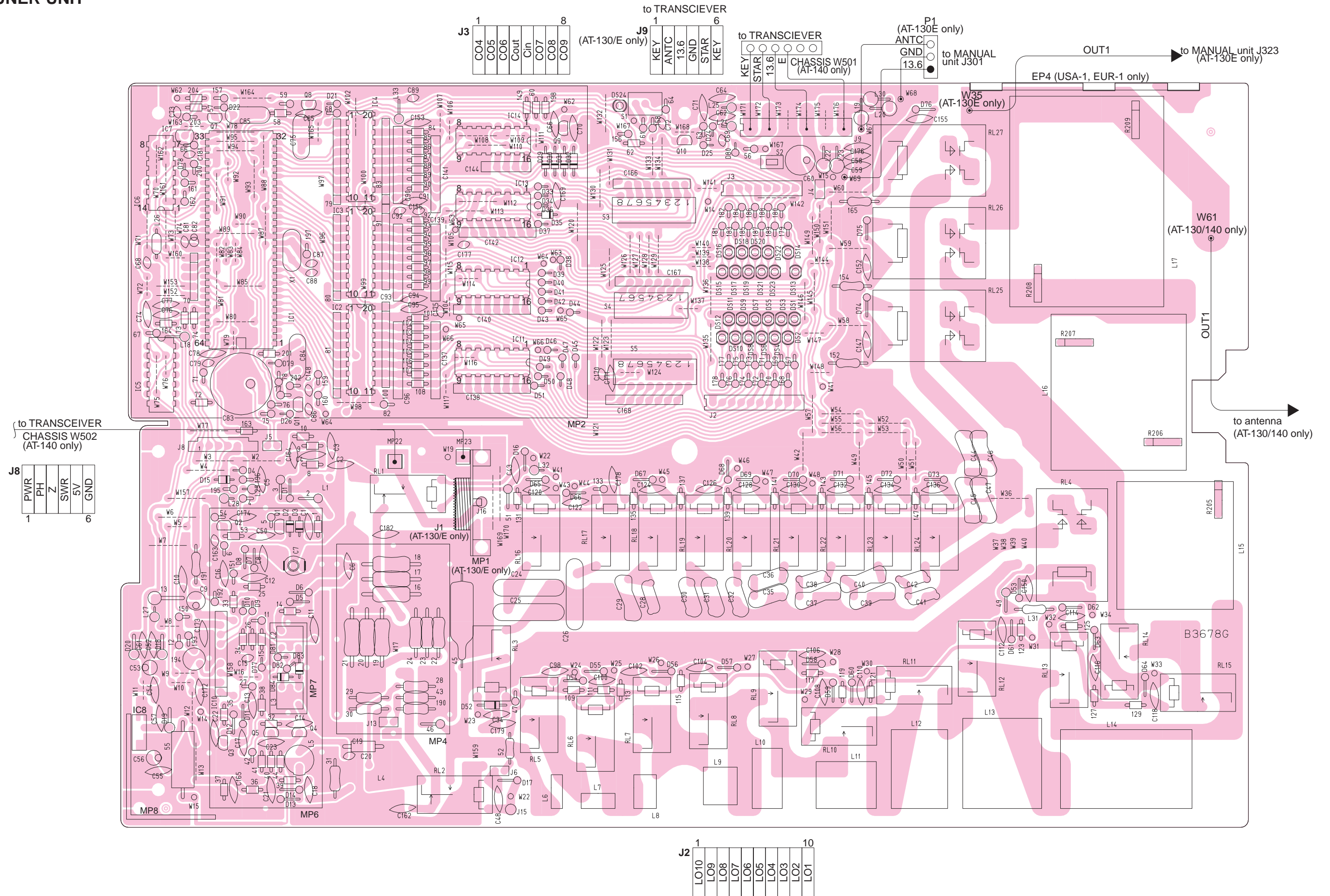

8-2 MANUAL UNIT (AT-130E ONLY)

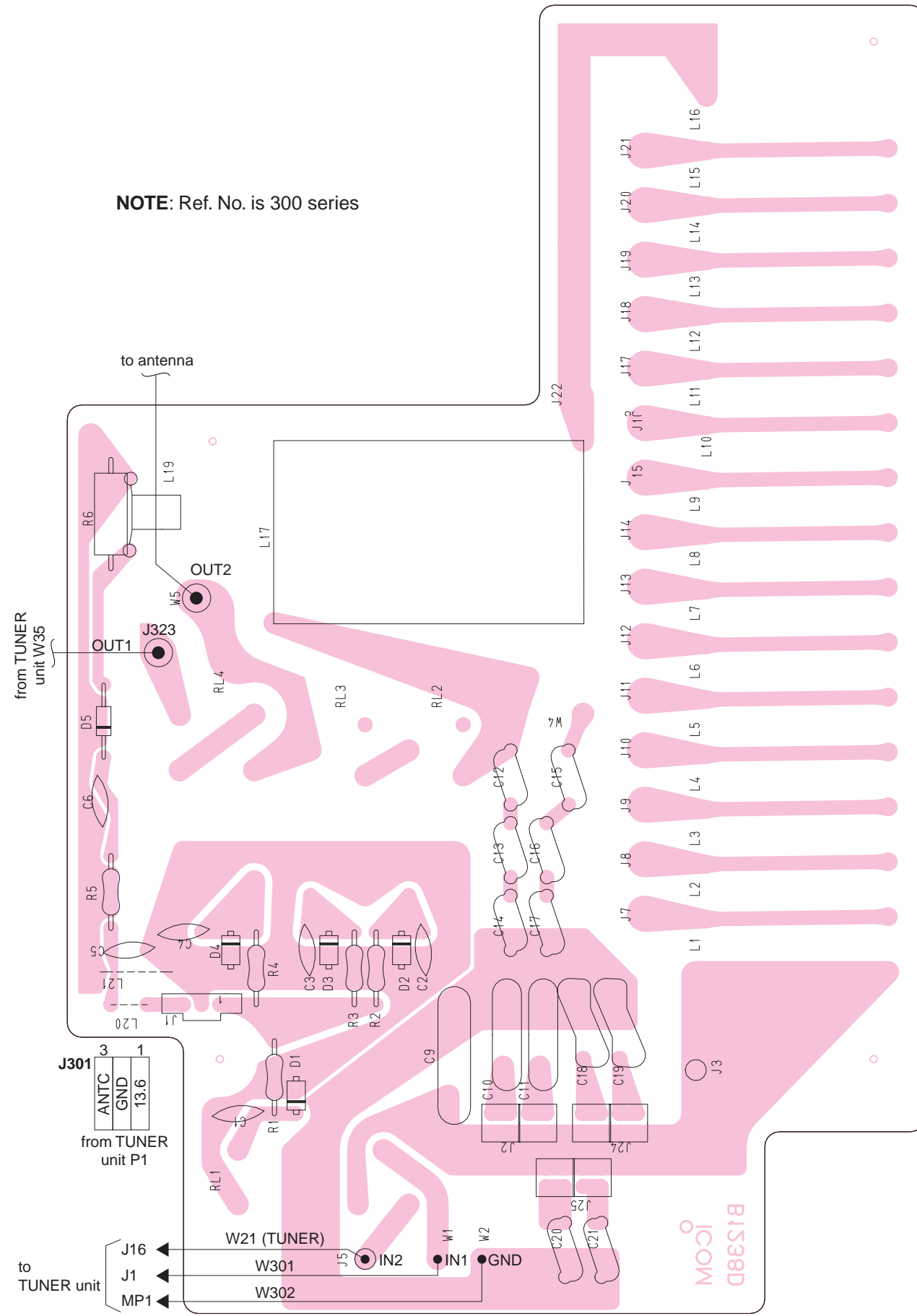

# SECTION 9 BLOCK DIAGRAM

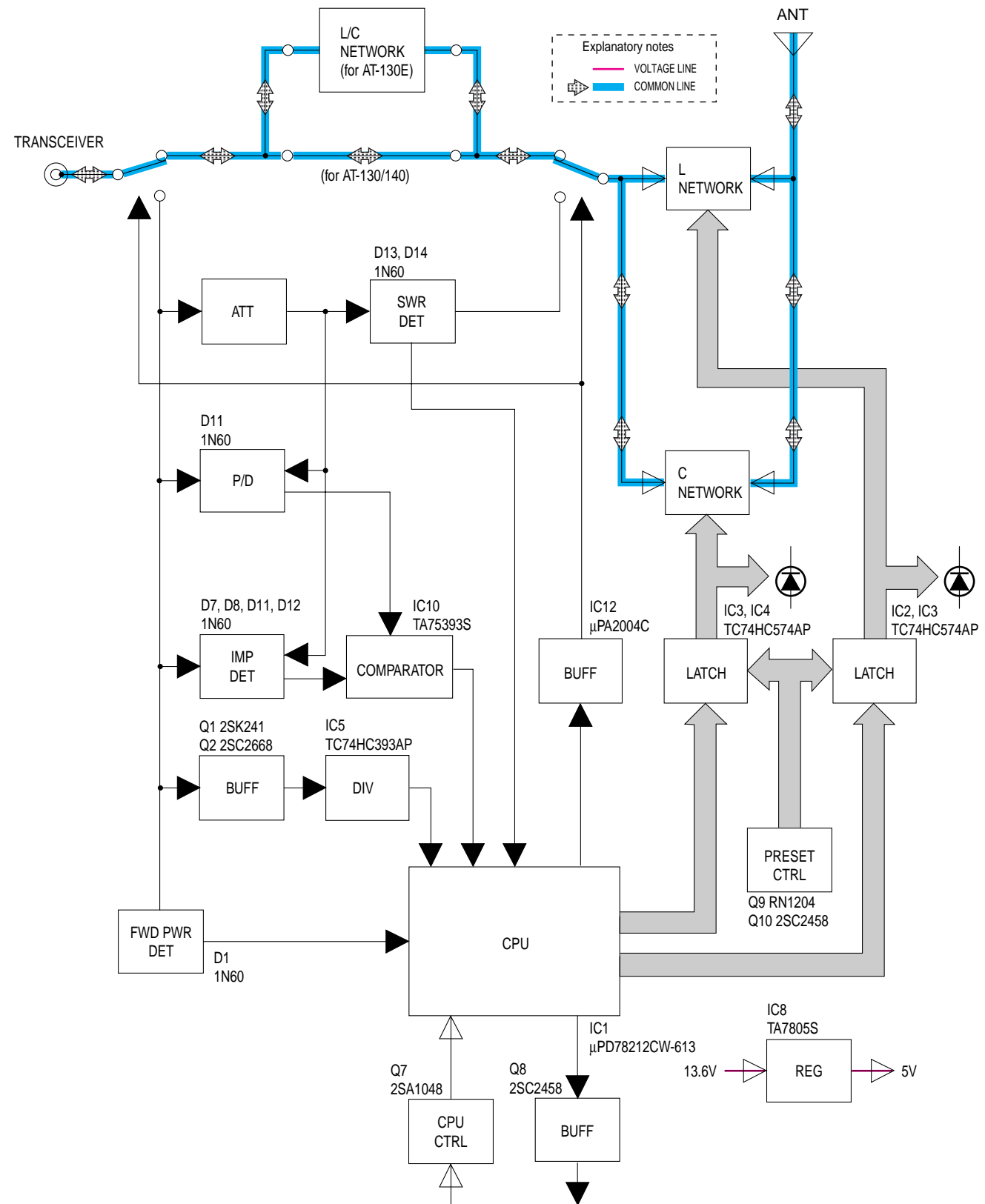



## Icom Inc.

1-1-32, Kamiminami, Hirano-ku, Osaka 547-0003, Japan  
Phone : +81 (06) 6793 5302  
Fax : +81 (06) 6793 0013  
URL : <http://www.icom.co.jp/world/index.html>

### Icom America Inc.

<Corporate Headquarters>  
2380 116th Avenue N.E., Bellevue, WA 98004, U.S.A.  
Phone : +1 (425) 454-8155 Fax : +1 (425) 454-1509  
URL : <http://www.icomamerica.com>  
E-mail : [sales@icomamerica.com](mailto:sales@icomamerica.com)  
<Customer Service>  
Phone : +1 (425) 454-7619

### Icom Canada

Glenwood Centre #150-6165  
Highway 17 Delta, B.C., V4K 5B8, Canada  
Phone : +1 (604) 952-4266 Fax : +1 (604) 952-0090  
URL : <http://www.icomcanada.com>  
E-mail : [info@icomcanada.com](mailto:info@icomcanada.com)

### Icom (Australia) Pty. Ltd.

Unit 1 / 103 Garden Road, Clayton VIC 3168 Australia  
Phone : +61 (03) 9549-7500 Fax : +61 (03) 9549-7505  
URL : <http://www.icom.net.au>  
E-mail : [sales@icom.net.au](mailto:sales@icom.net.au)

### Icom New Zealand

146A Harris Road, East Tamaki,  
Auckland, New Zealand  
Phone : +64 (09) 274 4062 Fax : +64 (09) 274 4708  
URL : <http://www.icom.co.nz>  
E-mail : [inquiries@icom.co.nz](mailto:inquiries@icom.co.nz)

### Beijing Icom Ltd.

10C07, Long silver Mansion, No.88, Yong Ding  
Road, Haidian District, Beijing, 100039, China  
Phone : +86 (010) 5889 5391/5392/5393  
Fax : +86 (010) 5889 5395  
E-mail : [bjicom@bjicom.com](mailto:bjicom@bjicom.com)  
URL : <http://www.bjicom.com>

### Icom Brazil

Rua Pernambuco, 353 - Sala 901, Belo Horizonte, M.G.  
30130-150, Brazil  
Phone : +55 (31) 3582 8847 Fax : +55 (31) 3582 8987  
E-mail : [sales@icombrasil.com](mailto:sales@icombrasil.com)

### Icom (Europe) GmbH

Communication Equipment  
Auf der Krautweide 24  
65812 Bad Soden am Taunus, Germany  
Phone : +49 (6196) 76685-0 Fax : +49 (6196) 76685-50  
URL : <http://www.icomeurope.com>  
E-mail : [info@icomeurope.com](mailto:info@icomeurope.com)

### Icom Spain S.L

Ctra. Rubi, No. 88 Bajos A 08174, Sant Cugat del Valles, Barcelona, Spain  
Phone : +34 (93) 590 26 70 Fax : +34 (93) 589 04 46  
URL : <http://www.icomspain.com>  
E-mail : [icom@icomspain.com](mailto:icom@icomspain.com)

### Icom (UK) Ltd.

Blacksale House, Altira Park, Herne Bay, Kent CT6 6GZ, UK  
Phone : +44 (0) 1227 741741 Fax : +44 (0) 1227 741742  
URL : <http://www.icomuk.co.uk>  
E-mail : [info@icomuk.co.uk](mailto:info@icomuk.co.uk)

### Icom France s.a.s.

Zac de la Plaine  
1 Rue Brindejonc des Moulinais BP 5804  
31505 Toulouse Cedex, France  
Phone : +33 (5) 61 36 03 03 Fax : +33 (5) 61 36 03 00  
URL : <http://www.icom-france.com>  
E-mail : [icom@icom-france.com](mailto:icom@icom-france.com)

### Asia Icom Inc.

6F No.68, Sec. 1 Cheng-Teh Road, Taipei, Taiwan, R.O.C.  
Phone : +886 (02) 2559 1899 Fax : +886 (02) 2559 1874  
URL : <http://www.asia-icom.com>  
E-mail : [sales@asia-icom.com](mailto:sales@asia-icom.com)

### Icom Polska

81-850 Sopot, ul. 3 Maja 54, Poland  
Phone : +48 (58) 550 7135 Fax : +48 (58) 551 0484  
E-mail : [icompolska@icompolska.com.pl](mailto:icompolska@icompolska.com.pl)



**Count on us!**

**Icom Inc.**

1-1-32, Kamiminami, Hirano-ku, Osaka 547-0003, Japan

S-14014HZ-C1  
© 2003 Icom Inc.